



H7-1200 PLC

Product Catalog

Shenzhen Huceen Automation Technology CO.,LTD

5F, NO.1 Building, Esun 3D Industrial Park, Zhongwu Community, Hangcheng Street, BaoAn District, Shenzhen.

+86 137 1399 0149 Caroline liu

info@huceen.com

www.huceen.com



HUCEEN is a registered trademark, and its copyright belongs to Shenzhen HUCEEN Automation Technology Co., LTD.
The Manual information is subject to change without prior notice, please refer to the latest manual. Printed version: HUCEEN-202604

About us

Founded in 2015, Shenzhen Huceen Automation Technology Co., Ltd. focuses on the R&D, production, sales, and technical services of core industrial automation products.

With a strong R&D team and extensive industry experience, HUCEEN delivers high-quality, high-performance, and cost-competitive automation products and integrated solutions.

The company has established an international sales and service network covering major cities in China and operates multiple overseas offices. Total product shipments have exceeded one million units, and HUCEEN has cooperated with more than 40 listed companies.

Mission

To help customers become industry leaders

Vision

To become a respected and global supplier of industrial automation products and solutions

Value

Integrity, specialty, innovation, sharing

Operation philosophy

Improve customers competitiveness continuously, we not only provide excellent products and services, but also supply customers with more industry knowledge and more professional technical solutions.

100W+

Quantity of shipment

40+

Cooperated Listed Company

100+

Sales and service network



National High-tech Enterprise



30+ Technology patents

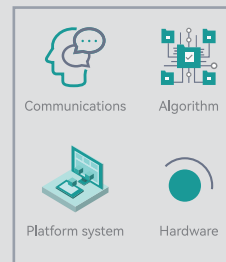

4 core technologies



Huceen product system

CATALOG

PLC

- E 200Smart
- E7 200Smart
- E5 200Smart
- E3 200Smart
- H7-1200
- Distributed Remote I/O



Internet of Things

- H-Box
- Smart Box
- IoT PLC E7 200 Smart
- HCloud industrial cloud platform



HMI

- Hpanel 7-inch
- Hpanel 10-inch



1、Summarize

- About Huceen ----- 01
- Company Vision ----- 02
- Product system ----- 03

3、Appendix

- Appendix1: H7-1200 CPU Wiring diagram -- 24
- Appendix2: H7-1200 Expansion module wiring layout ----- 25
- Appendix3: Ordering data ----- 27

2、H7-1200PLC

- H7-1200 Function characteristics ----- 05
- 1215C CPU ----- 09
- 1214C CPU ----- 13
- Digital input modules ----- 17
- Digital output modules ----- 18
- Digital input/output modules ----- 19
- Analog input modules ----- 20
- Analog output modules ----- 21
- Analog input/output modules ----- 22
- Temperature module ----- 23

4、Service and Warranty ----- 28

H7-1200 Series

Product Introduction

The H7-1200 series PLC is designed to promote intelligent manufacturing and meet the pain points of small and medium-sized automation complex application scenarios and industrial upgrading. It has the characteristics of fast speed, stable performance, flexible use, and powerful functionality.

CPU Port Diagram



Function Features

Integration with TIA Portal Ecosystem

Engineers can choose to use TIA Portal for fast and intuitive development and debugging of automation systems according to their project requirements. No need to change programming habits, making it easy to get started quickly and master.



Powerful Expansion Capability

The 1215C CPU can connect to up to 16 I/O slave devices simultaneously, meeting the requirements of distributed control in complex industrial scenarios. It supports real-time data interaction of up to 4096 I/O points, ensuring stability and responsiveness in high-density control tasks. It is compatible with Huceen economical HD 200Smart series, high-performance compact HD 200SP series, intelligent slaves such as the E7 200Smart series, as well as other third-party standard Profinet slave devices.

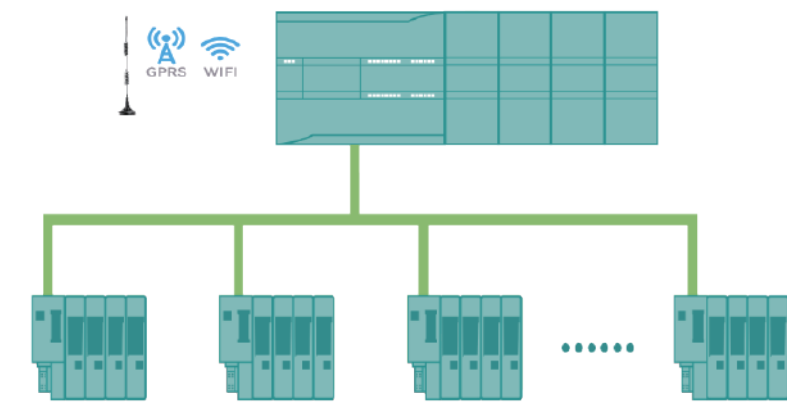

Easy Installation

The H7-1200 series comes with built-in mounting clips, allowing easy installation on standard 35mm DIN rails. The PLC can be installed either vertically or horizontally.

All H7-1200 series hardware is equipped with standard 4mm removable quick-connect terminals. Engineers only need to wire once, saving valuable time and reducing wiring errors during project commissioning, debugging, and maintenance.

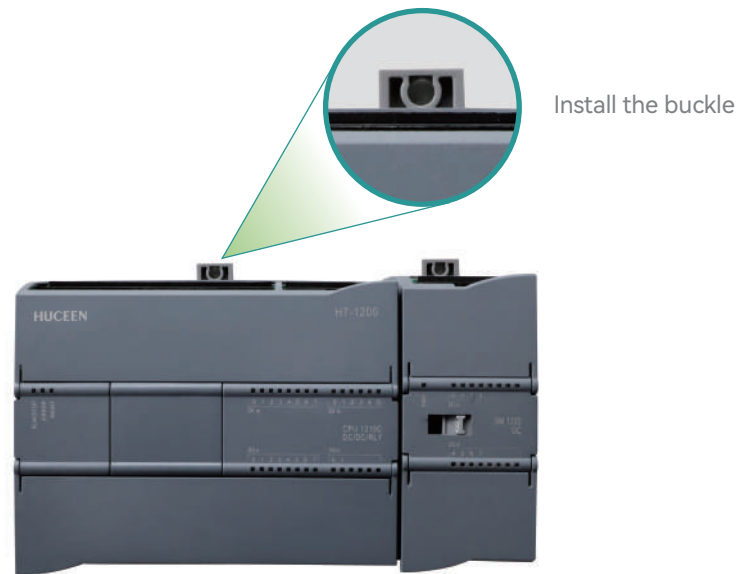

Electrical Isolation

The H7-1200 series AI/AO modules have increased electrical isolation between the channel detection circuit and the module backplane circuit. In the event of high voltage entering the module channels or power supply, only the detection circuit of the module would be damaged, while the backplane circuit remains unaffected. This ensures that PLC modules on the same rack are protected from high-voltage damage.

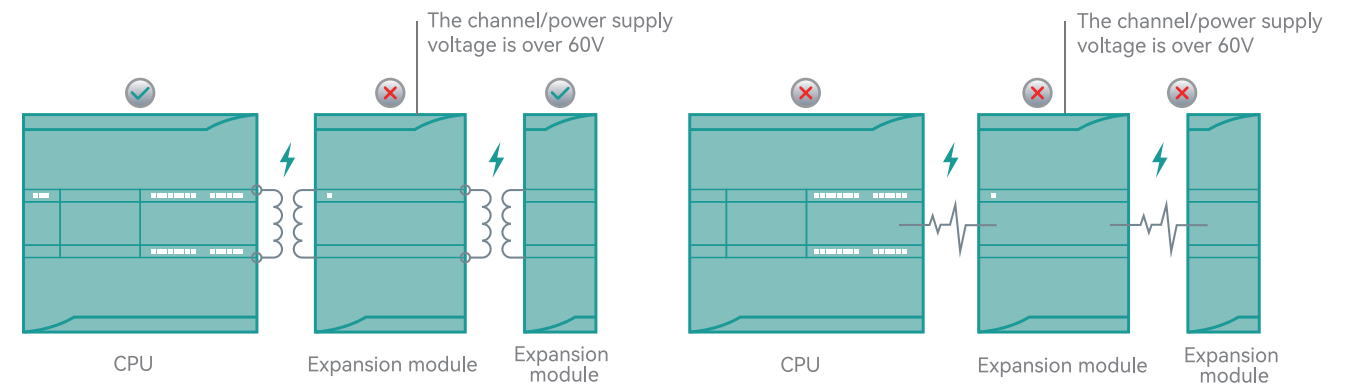

Add electrical isolation

Non-electrical isolation

In the absence of electrical isolation, the overload current of the module will be transmitted through the backplane to all the PLCs in the entire rack, it will be resulting in damage.

Convenient Firmware Updates

Supports standard SD card program loading, firmware refreshing and storage expansion. No need for dedicated TF cards.



1215C CPU

Model	CPU 1215C DC/DC/RLY	CPU 1215C DC/DC/DC
Order No.	H7 215-1HG31-0XB0	H7 215-1AG31-0XB0
Picture		
Standard		
Dimensions W × H × D (mm)	130×100×75	
Weight:	585 g	520 g
Power Loss, Typ.	12 W	
Available Current (SM and CM Bus)	Max. 1600 mA (5 VDC)	
Available Current (24 VDC)	Max. 400 mA (Sensor Power)	
Digital Input Current Consumption (24 VDC)	4 mA per input point	
CPU Features		
User Memory		
Working	250 KB	
Load	Built-in 4 MB	
Retention	10 KB	
Onboard Digital I/O	14 inputs / 10 outputs	
Onboard Analog I/O	2 inputs / 2 outputs	
Process Image Size	1024 bytes input (I) / 1024 bytes output (Q)	
Bit Memory (M)	8192 bytes	
Temporary (Local) Memory	16 KB for startup and program cycle (including FBs and FCs) 4 KB for standard interrupt events (including FBs and FCs) 4 KB for error interrupt events (including FBs and FCs)	
Signal Module Expansion	Up to 8 signal modules	
SB, CB, BB Expansion	Up to 1	
Communication Module Expansion	Not supported	
High-Speed Counters	6 total Single-phase: 3 x 100 kHz (Ia.0 to Ia.5) and 3 x 30 kHz (Ia.6 to Ib.5) Quadrature phase: 3 x 80 kHz (Ia.0 to Ia.5) and 3 x 20 kHz (Ia.6 to Ib.5)	
Pulse Output	-	Up to 4 can be configured: 100 kHz (Qa.0 and Qa.2) 20 kHz (Qa.4 and Qa.6)
Pulse Capture Inputs	14	
Timed / Cyclic Interrupts	4, with 1 ms accuracy	
Edge Interrupts	12 rising edges and 12 falling edges	
Memory Card	Supports TF cards (firmware upgrades)	
Real-Time Clock Accuracy	±60 s/month	
RTC Retention	Typically 20 days, minimum 12 days at 40°C (maintenance-free super capacitor)	
Performance		
Boolean Operation Speed ^{Note 1}	0.26 μs/instruction	
Word Move Speed ^{Note 1}	0.43 μs/instruction	
Floating-Point Add Speed ^{Note 1}	1.36 μs/instruction	

Note 1: Many variables affect the measurement time. The above performance times apply to this class and the fastest instructions in an error-free program.

Communication	
Ports	2
Type	Ethernet
HMI Devices	4
Programming Device (PG)	1
Connections	<ul style="list-style-type: none"> • 8 for open user communication (active or passive): TSEND_C, TRCV_C, TCON, TDISCON, TSEND, TRCV • 8 for server GET/PUT (CPU-to-CPU S7 communication) • 8 for client GET/PUT (CPU-to-CPU S7 communication)
Data Transfer Rate	10/100 Mb/s
Isolation (External Signal vs PLC Logic)	Transformer isolation, 1500V AC (short-term event only)
Cable Type	Shielded CAT5e
Power Supply	
Voltage Range	20.4 — 28.8 VDC
Power frequency	-
Input Current (Max)	
CPU only	500 mA at 24 VDC
CPU with all expansions	1500 mA at 24 VDC
Surge Current (Max)	12 A at 28.8 VDC
Isolation (Input Power vs Logic)	None
Leakage current, AC line to functional ground	-
Hold Time (Power Loss)	10 ms at 24 VDC
Internal Fuse (User Non-Replaceable)	3 A, 60 V, PTC self-resetting
Sensor Power	
Voltage Range	L + - 4 VDC (min)
Rated Output Current (Max)	400 mA (short-circuit protected)
Maximum Ripple (<10 MHz)	Same as input line
Isolation (CPU Logic vs Sensor Power)	None

1215C CPU

Digital Inputs		
Number of Inputs	14	
Type	Sink/Source (IEC Class 1 Sink)	
Rated Voltage	24 VDC at 4 mA	
Permissible Continuous Voltage	Max 35 VDC	
Surge Voltage	60 VDC for 1 min	
Logic 1 Signal (Min)	15 VDC at 2.5 mA	
Logic 0 Signal (Max)	5 VDC at 1 mA	
Isolation (Field side vs. Logic side)	500 VAC, 1 min continuous	
Isolation group	1	
Filter time	0.2, 0.4, 0.8, 1.6, 3.2, 6.4, and 12.8 ms (selectable, 4 per group)	
Maximum HSC clock input frequency (Logic 1 level = 15 to 26 VDC)	Single-phase: 100 kHz (Ia.0 to Ia.5) and 30 kHz (Ia.6 to Ib.5) Quadrature phase: 80 kHz (Ia.0 to Ia.5) and 20 kHz (Ia.6 to Ib.5)	
Number of simultaneously active inputs	<ul style="list-style-type: none"> • 7, No adjacent points, 60°C (horizontal) or 50°C (vertical) • 14, 55°C (horizontal) or 45°C (vertical) 	
Cable length (m)	500 m (shielded); 300 m (unshielded); 50 m (shielded, HSC input)	
Digital Outputs		
Number of outputs	10	
Type	Relay, dry contact	Solid-state - MOSFET (source type)
Voltage range	5 to 30 VDC or 5 to 250 VAC	20.4 — 28.8 V DC
Logic 1 voltage at max. current	-	Min 20 VDC
Logic 0 voltage with 10 kΩ load	-	Max 0.1 VDC
Current (max)	2.0 A	0.5 A
Lamp load	30 W DC / 200 W AC	5 W
On-state resistance	Max 0.2 Ω (new device)	Max 0.6 Ω
Leakage current per point	-	Max 10 μA
Surge current	7 A when contacts closed	8 A, lasting up to 100 ms
Overload protection	None	
Isolation (Field side vs. Logic side)	1500 VAC, 1 min (coil-to-contact); None (coil-to-logic)	500 VAC, 1 min
Insulation between contacts	750 VAC, 1 min	-
Isolation group	2	1
Inductive clamping voltage	-	L+ - 48 V DC, 1W power loss
Switching delay (Qa.0 to Qa.3)	Max 10 ms	The longest time from disconnect to connection is 1.0 μs. The longest time from connection to disconnect is 3.0 μs.
Switching delay (Qa.4 to Qb.1)	Max 10 ms	The longest time from disconnect to connection is 5 μs. The longest time from connection to disconnect is 200 μs.
Maximum relay switching frequency	1 Hz	-
Pulse train output frequency (Qa.0 and Qa.2)	Not recommended	100 kHz (Qa.0 to Qa.2) 20 kHz (Qa.3)
Mechanical lifetime (no load)	10,000,000 make/break cycles	-
Contact lifetime at rated load	100,000 make/break cycles	-
RUN-to-STOP behavior	Previous value or replacement (default = 0)	
Number of simultaneously active outputs	<ul style="list-style-type: none"> • 5, No adjacent points, 60°C (horizontal) or 50°C (vertical) • 10, 55°C (horizontal) or 45°C (vertical) 	
Cable length (m)	500 m (shielded); 150 m (unshielded)	

Analog Inputs	
Number of input channels	2
Type	Voltage (single-ended)
Full-scale range	0 to 10 V
Full-scale range (digital value)	0 to 27,648
Overshoot range	10,001 to 11,759 V
Overshoot range (digital value)	27,649 to 32,511
Overflow range	11,760 to 11,852 V
Overflow (digital value)	32,512 to 32,767
Resolution	10-bit
Maximum withstand voltage	60VDC 1min (Class B standard)
Smoothing	None / Weak / Medium / Strong
Noise suppression	10 / 50 / 60 Hz
Input impedance	≥100 kΩ
Isolation (field vs. logic)	None
Accuracy (25 °C / -20 to 60 °C)	0.5% / 1.0% of full scale
Cable length (m)	100 m, shielded twisted pair
Analog Outputs	
Number of outputs	2
Type	Current
Range	0 to 20 mA
Full-scale range (digital value)	0 to 27,648
Maximum voltage/ current rating	60 VDC / 40 mA 1min (Class B standard)
Overshoot range	20.01 to 23.52 mA
Overshoot range (digital value)	27,649 to 32,511
Overflow range	On overflow, analog output behavior follows device configuration. For the "Response to CPU STOP" parameter, choose either replacement value or hold previous value.
Overflow range (digital value)	32,512 to 32,767
Resolution	10-bit
Output driving impedance	Max 700 Ω
Isolation (field vs. logic)	None
Accuracy (25°C / -20 to 60°C)	0.5% / 1.0% of full scale
Stabilization time	2 ms
Cable length (m)	100 m, shielded twisted pair

1214C CPU

Model	CPU 1214C DC/DC/Relay
Order No.	H7 214-1HG31-0XB0
Picture	
Standard	
Dimensions W × H × D (mm)	110 x 100 x 75
Weight	435g
Power Loss, Typ.	12 W
Available Current (SM and CM Bus)	Max. 1600 mA (5 VDC)
Available Current (24 VDC)	Max. 400 mA (Sensor Power)
Digital Input Current Consumption (24 VDC)	4 mA per input point
CPU Features	
User Memory	
Working	200 KB
Load	Built-in 4 MB
Retention	10 KB
Onboard Digital I/O	14 inputs / 10 outputs
Onboard Analog I/O	2 inputs
Process Image Size	1024 bytes input (I) / 1024 bytes output (Q)
Bit Memory (M)	8192 bytes
Temporary (Local) Memory	16 KB for startup and program cycle (including FBs and FCs) 4 KB for standard interrupt events (including FBs and FCs) 4 KB for error interrupt events (including FBs and FCs)
Signal Module Expansion	Up to 8 signal modules
SB, CB, BB Expansion	Up to 1
Communication Module Expansion	Not supported
High-Speed Counters	6 total Single-phase: 3 x 100 kHz (Ia.0 to Ia.5) and 3 x 30 kHz (Ia.6 to Ib.5) Quadrature phase: 3 x 80 kHz (Ia.0 to Ia.5) and 3 x 20 kHz (Ia.6 to Ib.5)
Pulse Output	/
Pulse Capture Inputs	14
Timed / Cyclic Interrupts	4, with 1 ms accuracy
Edge Interrupts	12 rising edges and 12 falling edges
Memory Card	Supports TF cards (firmware upgrades)
Real-Time Clock Accuracy	±60 s/month
RTC Retention	Typically 20 days, minimum 12 days at 40°C (maintenance-free super capacitor)
Performance	
Boolean Operation Speed ^{Note 1}	0.26 μs/instruction
Word Move Speed ^{Note 1}	0.43 μs/instruction
Floating-Point Add Speed ^{Note 1}	1.36 μs/instruction

Note 1: Many variables affect the measurement time. The above performance times apply to this class and the fastest instructions in an error-free program.

Communication	
Ports	1
Type	Ethernet
HMI Devices	4
Programming Device (PG)	1
Connections	<ul style="list-style-type: none"> • 8 for open user communication (active or passive): TSEND_C, TRCV_C, TCON, TDISCON, TSEND, TRCV • 8 for server GET/PUT (CPU-to-CPU S7 communication) • 8 for client GET/PUT (CPU-to-CPU S7 communication)
Data Transfer Rate	10/100 Mb/s
Isolation (External Signal vs PLC Logic)	Transformer isolation, 1500V AC (short-term event only)
Cable Type	Shielded CAT5e
Power Supply	
Voltage Range	20.4 — 28.8 VDC
Power frequency	-
Input Current (Max)	
CPU only	500 mA at 24 VDC
CPU with all expansions	1500 mA at 24 VDC
Surge Current (Max)	12 A at 28.8 VDC
Isolation (Input Power vs Logic)	None
Hold Time (Power Loss)	10 ms at 24 VDC
Internal Fuse (User Non-Replaceable)	3 A, 60 V, PTC self-resettin
Sensor Power	
Voltage Range	L + - 4 VDC (min)
Rated Output Current (Max)	400 mA (short-circuit protected)
Maximum Ripple (<10 MHz)	Same as input line
Isolation (CPU Logic vs Sensor Power)	None

1214C CPU





Digital Inputs	
Number of Inputs	14
Type	Sink/Source (IEC Class 1 Sink)
Rated Voltage	24 VDC at 4 mA
Permissible Continuous Voltage	Max 35 VDC
Surge Voltage	60 VDC for 1 min
Logic 1 Signal (Min)	15 VDC at 2.5 mA
Logic 0 Signal (Max)	5 VDC at 1 mA
Isolation (Field side vs. Logic side)	500 VAC, 1 min continuous
Isolation group	1
Filter time	0.2, 0.4, 0.8, 1.6, 3.2, 6.4, and 12.8 ms (selectable, 4 per group)
Maximum HSC clock input frequency (Logic 1 level = 15 to 26 VDC)	Single-phase: 100 kHz (Ia.0 to Ia.5) and 30 kHz (Ia.6 to Ib.5) Quadrature phase: 80 kHz (Ia.0 to Ia.5) and 20 kHz (Ia.6 to Ib.5)
Number of simultaneously active inputs	<ul style="list-style-type: none"> • 7, No adjacent points, 60°C (horizontal) or 50°C (vertical) • 14, 55°C (horizontal) or 45°C (vertical)
Cable length (m)	500 m (shielded); 300 m (unshielded); 50 m (shielded, HSC input)
Digital Outputs	
Number of outputs	10
Type	Relay, dry contact
Voltage range	5 to 30 VDC or 5 to 250 VAC
Logic 1 voltage at max. current	-
Logic 0 voltage with 10 kΩ load	-
Current (max)	2.0 A
Lamp load	30 W DC / 200 W AC
On-state resistance	Max 0.2 Ω (new device)
Leakage current per point	-
Surge current	7 A when contacts closed
Overload protection	None
Isolation (Field side vs. Logic side)	1500 VAC, 1 min (coil-to-contact); None (coil-to-logic)
Insulation between contacts	750 VAC, 1 min
Isolation group	2
Inductive clamping voltage	-
Switching delay (Qa.0 to Qa.3)	Max 10 ms
Switching delay (Qa.4 to Qb.1)	Max 10 ms
Maximum relay switching frequency	1 Hz
Pulse train output frequency (Qa.0 and Qa.2)	Not recommended
Mechanical lifetime (no load)	10,000,000 make/break cycles
Contact lifetime at rated load	100,000 make/break cycles
RUN-to-STOP behavior	Previous value or replacement (default = 0)
Number of simultaneously active outputs	<ul style="list-style-type: none"> • 5, No adjacent points, 60°C (horizontal) or 50°C (vertical) • 10, 55°C (horizontal) or 45°C (vertical)
Cable length (m)	500 m (shielded); 150 m (unshielded)

Analog Inputs	
Number of input channels	2
Type	Voltage (single-ended)
Full-scale range	0 to 10 V
Full-scale range (digital value)	0 to 27,648
Overshoot range	10.001 to 11.759 V
Overshoot range (digital value)	27,649 to 32,511
Overflow range	11.760 to 11.852 V
Overflow (digital value)	32,512 to 32,767
Resolution	10-bit
Maximum withstand voltage	60VDC 1min (Class B standard)
Smoothing	None / Weak / Medium / Strong
Noise suppression	10 / 50 / 60 Hz
Input impedance	≥100 kΩ
Isolation (field vs. logic)	None
Accuracy (25 °C / -20 to 60 °C)	0.5% / 1.0% of full scale
Cable length (m)	100 m, shielded twisted pair

Digital input modules

Model No.	SM 1221 DI 8x24 V DC	SM 1221 DI 16x24 V DC
Order No.	H7 221-1BF32-0XB0	H7 221-1BH32-0XB0
Picture		
Product Description	digital input module DI8 x 24V DC , sinking/sourcing type	digital input module DI16 x 24V DC , sinking/sourcing type
Standard	45x100x75mm	
Power Consumption	1.5W	2.5W
Current Consumption (SM bus)	105mA	130mA
Current Consumption (24V DC)	4mA for each input point used	
Digital input		
Number of Inputs	8	16
Input Type	The sinking type /sourcing type	
Rated Voltage	24V DC at 4mA, Rated Value	
Allowable Continuous Voltage	max. 30VDC	
Surge Voltage(Max)	35V DC, lasting 0.5s	
Logic 1 Signal (Min)	15V DC at 2.5mA	
Logic 0 Signal (Max)	5V DC at 1mA	
Optical Isolation (field side and logic side)	500V AC, lasting 1 min	
Isolation Group	2	4
Filter time	0.2, 0.4, 0.8, 1.6, 3.2, 6.4 and 12.8 ms (optional, 4 inputs form one group)	



Digital output modules

Model No.	SM 1222 DQ 8x24 V DC	SM 1222 DQ 16x24 V DC	SM 1222 DQ 8xRLY	SM 1222 DQ 16xRLY
Order No.	H7 222-1BF32-0XB0	H7 222-1BH32-0XB0	H7 222-1HF32-0XB0	H7 222-1HH32-0XB0
picture				
Product Description	digital output module DQ8 x 24VDC, Transistor	digital output module DQ16 x 24VDC, Transistor	digital output module DQ8 x Relay	digital output module DQ16 x Relay
Standard	45x100x75			
Dimension (W×H×D)	45x100x75			
Power Consumption	1.5W	2.5W	4.5W	8.5W
Current Consumption (SM bus)	120mA	140mA	120mA	135mA
Current Consumption (24V DC)	50mA	100mA	Each relay coil used is 11mA	
Digital Output				
Number of Outputs	8	16	8	16
Output Type	Solid-MOSFET (source type)		Relay, dry contact	
Voltage Range	20.4-28.8V DC		5-30V DC or 5-250V AC	
Logic 1 Signal at Maximum Current	min 20V DC		-	
Logic 0 Signal with 10KΩ Load	max 0.1V DC		-	
Electric Current (Max)	0.5A		2A	
Lamp Load	5W		30W DC/200W AC	
Flood Leakage Current of Each Point	Maximum 10μA		-	
Surge Current	8A, max. lasting 100ms		it is 7A when the contact is closed	
Isolation(field side and logic side)	500V AC, lasting 1 min		1500V AC, lasting 1 min(Coil and contact) ; None(coil and logic side)	
Isolation Group	1		2	4
Current of Each Public Terminal (Max)	4A	8A	10A	
Switching Delay	from the disconnection to connection(Max): 50μs; from the connection to disconnection(Max): 200μs		Up to 10ms	
Mechanical Lifetime (non-responsible)	-		10,000,000 break/close cycles	
Lifetime under Rated Load	-		100,000 break/close cycles	
Behavior at RUN-STOP	previous value or replacement value (default is 0)			

Digital input/output modules

Model No.	SM 1223 DI 8x24 V DC DQ 8x24 V DC	SM 1223 DI 16x24 V DC DQ 16x24 V DC	SM 1223 DI 8x24 V DC DQ 8xRLY	SM 1223 DI 16x24 V DC DQ 16xRLY
Order No.	H7 223-1BH32-0XB0	H7 223-1BL32-0XB0	H7 223-1PH32-0XB0	H7 223-1PL32-0XB0
Picture				
Product Description	digital input & output module DI8 x 24V DC sinking /sourcing type & DQ8 x 24V DC, Transistor output	digital input & output module DI16 x 24V DC sinking/sourcing type & DQ16 x 24V DC, Transistor output	digital input & output module DI8 x 24V DC sinking/sourcing type & DQ8 x relay, relay output	digital input & output module DI16 x 24V DC sinking/sourcing type & DQ16 x relay, relay output
Standard				
Dimension (W×H×D)	45x100x75	70x100x75	45x100x75	70x100x75
Power Consumption	2.5W	4.5W	5.5W	10W
Current Consumption (SM bus)	145mA	185mA	145mA	180mA
Current Consumption (24V DC)	4mA for each input point used		4mA for each input point used, each relay coil used is 11mA	
Digital Input				
Number of Inputs	8	16	8	16
Input Type	The sinking /sourcing type			
Surge Voltage	35V DC, lasting 0.5s			
Logic 1 Signal (Min)	15V DC at 2.5mA			
Logic 0 Signal (Max)	5V DC at 1mA			
Optical Isolation (field side and logic side)	500 V AC, lasting 1 min			
Isolation Group	2			
Filter Time	0.2, 0.4, 0.8, 1.6, 3.2, 6.4 and 12.8 ms (optional, 4 inputs form one group)			
Digital Output				
Number of Outputs	8	16	8	16
Output Type	Solid-MOSFET (source type)		Relay, dry contact	
Voltage Range	20.4~28.8V DC		5-30V DC or 5-250V AC	
Logic 1 Signal at Maximum Current	min 20V DC		-	
Logic 0 Signal with 10KΩ Load	max 0.1V DC		-	
Electric Current (Max)	0.5A		2A	
Lamp Load	5W		30W DC/200W AC	
Flood Leakage Current of Each Point	max 10μA		-	
Surge Current	8A, max. lasting 100ms		it is 7A when the contact is closed	
Isolation (field side and logic side)	500V AC, lasting 1 min		1500V AC, lasting 1 min(Coil and contact) ; None(coil and logic side)	
Isolation Group	1		2	4
Current of Each Public Terminal (Max)	4A	8A	10A	8A
Switching Delay	from the disconnection to connection(Max): 50μs; from the connection to disconnection(Max): 200μs		Up to 10ms	
Mechanical Lifetime (non-responsible)	-		10,000,000 break/close cycles	
Lifetime under Rated Load	-		100,000 break/close cycles	
Behavior at RUN-STOP	previous value or replacement value (default is 0)			

Analog input modules

Model No.	SM1231 AI4 x 13 Bits	SM1231 AI8 x 13 Bits	SM1231 AI4 x 16 Bits
Order No.	H7 231-4HD32-0XB0	H7 231-4HF32-0XB0	H7 231-5ND32-0XB0
Picture			
Product Description	Analog input module AI4 x 13 bits	Analog input module AI8 x 13 bits	Analog input module AI4 x 16 bits
Standard			
Dimension (W×H×D)	45x100x75mm		
Power Consumption	2.2W	2.3W	2.0W
Current Consumption (SM bus)	80mA	90mA	80mA
Current Consumption (24V DC)	45mA		65mA
Analog Input			
Number of Inputs	4	8	4
Input Type	voltage or current (differential): 2 can be selected as a group range		Voltage or current (differential)
Input Range	±10V, ±5V, ±2.5V or 0—20mA		±10V, ±5V, ±2.5V, ±1.25V, 0—20mA or 4—20 mA
Full scale Range (Data Word)	-27648—27648		
Overshoot/undershoot Range (Data Word)	Voltage: 32,511—27,649/-27,649 — -32,512 Current: 32,511—27,649/0 — -4,864		Voltage: 32,511—27,649/-27,649 — -32,512 Current 0—20mA: 32,511—27,649/0 — -4,864; 4—20mA: 32,511—27,649/-1 — -4,864
Overflow/Underflow (Data Word)	Voltage: 32,767—32,512/-32,513 — -32,768 Current: 32,767—32,512/-4,865 — -32,768		Voltage: 32,767—32,512/-32,513 — -32,768 Current 0—20mA: 32,767—32,512/-4,865 — -32,768; 4—20mA: 32,767—32,512/-4,865 — -32,768
Data format	12 bits + signal bits		15 bits + signal bits
Max. Voltage/Current Resistance	±60V/±40mA		
Smoothness	None, weak, medium or strong		
Noise Suppression	400、60、50 or 10Hz		
Isolation(field side and logic side)	None		
Precision(25°C/0-55°C)	full range ±0.1%/±0.2%		full range ±0.1%/±0.3%
Working Signal Range	signal plus common mode voltage must be <+12V and >-12V		
Diagnosis: Overflow/underflow	Support		
Circuit Break(Current Mode Only)	not applicable		4—20mA range only (If input is below -4,164; 1.0mA)

Analog output modules





Model No.	SM1232 AQ2 x 14 Bits	SM1232 AQ4 x 14 Bits
Order No.	H7 232-4HB32-0XB0	H7 232-4HD32-0XB0
Picture		
Product Description	analog output module AQ2 x 14 bits	analog output module AQ4 x 14 bits
Standard		
Dimension (W×H×D)	45x100x75mm	
Power Consumption	1.5W	
Current Consumption (SM bus)	80mA	
Current Consumption (24V DC)	45mA (no load)	
Analog Output		
Number of Outputs	2	4
Output Type	Voltage or current	
Output Range		
Current Output	0—20mA or 4—20mA	
Voltage Output	±10 V	
Data Word Format		
Voltage	-27648—27648	
Current	0-27648	
Resolution		
Voltage Mode	14 bits	
Current Mode	13 bits	
Max. Voltage Resistance	±60 V	
Isolation (field side and logic side)	500VAC	
Precision (25°C/0-55°C)	full range ±0.3% /±0.6%	
Stability Time	Voltage: 300μS(R), 750μS(1 uF); Current: 600μS(1 mH), 2 ms(10 mH)	
Load Impedance	Voltage: ≥ 1000 Ω; Current: ≤ 600 Ω	
Output Status in STOP Mode	previous value or replacement value (default is 0)	
Diagnosis		
Overflow/underflow	Support	
Voltage Mode: short circuit to ground	Support	
Current Mode: Circuit break mode	Support	

Analog input/output modules

Model No.	SM1234 AI4 x 13 Bits & AQ2 x 14 Bits		
Order No.	H7 234-4HE32-0XB0		
Picture			
Product Description	Analog input & output module AI4 + AQ2, Input: 13 bits		
Standard			
Dimension (W×H×D)	45x100x75mm		
Power Consumption	2W		
Current Consumption (SM bus)	80mA		
Current Consumption (24V DC)	60mA(no load)		
Analog Input			
Number of Inputs	4		
Input Type	voltage or current (differential): 2 can be selected as a group range		
Input Range	±10V, ±5V, ±2.5V, 0—20mA or 4—20mA		
Full scale Range (Data Word)	-27648-27648		
Overshoot/undershoot Range (Data Word)	Voltage: 32,511—27,649/-27,649 — -32,512; Current: 32,511—27,649/0 — -4864		
Overflow/Underflow (Data Word)	Voltage: 32,767—32,512/-32,513 — -32,768; Current: 32,767—32,512/-4865 — -32,768		
Resolution	12 bits + signal bits		
Max Voltage/Current Resistance	±60V/±40mA		
Precision (25°C/0-55°C)	full range ±0.1 %/±0.2 %		
Analog to digital Conversion Time	625μs (400 Hz inhibited)		
Working Signal Range	signal plus common mode voltage must be <+12V and >-12V		
Common mode Rejection	40dB, DC—60Hz		
Analog Output			
Number of Outputs	2		
Output Type	Voltage or current	Isolation (field side and logic side)	500VAC
Output Range	±10V, 0—20mA or 4—20mA	Precision (25°C/0-55°C)	full range ±0.3% /±0.6%
Current Output	0—20mA or 4—20mA	Stability Time	Voltage: 300μS(R), 750μS(1 uF); Current: 600μS(1 mH), 2 ms(10 mH)
Voltage Output	±10 V	Load Impedance	Voltage: ≥ 1000 Ω; Current: ≤ 600 Ω
Data Word Format		Output Status in STOP Mode	previous value or replacement value (default is 0)
Voltage	-27648-27648	Diagnosis	
Current	0-27648	Overflow/underflow	Support
Resolution		Voltage Mode: short circuit to ground	Support
Voltage Mode	14 bits	Current Mode: circuit break mode	Support
Current Mode	13 bits		
Max Voltage Resistance	±60 V		

Temperature modules

Appendix1: H7-1200 CPU Wiring diagram

Model No.	SM1231 AI4 x 16 Bits TC	SM1231 AI8 x 16 Bits TC	SM1231 AI4 x 16 Bits RTD	SM1231 AI8 x 16 Bits RTD
Order No.	H7 231-5QD32-0XB0	H7 231-5QF32-0XB0	H7 231-5PD32-0XB0	H7 231-5PF32-0XB0
Picture				
Product Description	Analog input module AI4 x TC	Analog input module AI8 x TC	Analog input module AI4 x RTD	Analog input module AI8 x RTD
Standard				
Dimension (W×H×D)	45x100x75		70x100x75	
Power Consumption	1.5W			
Current Consumption (SM bus)	80mA		90mA	
Current Consumption (24V DC)	40mA			
Analog Input				
Number of Inputs	4	8	4	8
Input Type	TC		RTD and Resistance	
Type	J, K, T, E, R, S, B, N, C, TXK/XK (L) , Voltage Range: +/-80 mv		Platinum (Pt), copper (Cu), nickel (Ni), LG-Ni or resistance	
Resolution	0.1 °C/0.1 °f			
Temperature	15 bits + signal bits			
Resistance	Max. ±60V			
Voltage Resistance	500VAC			
Isolation	85dB at 10Hz/50Hz/60Hz/400Hz			
Channel to channel Isolation	120V AC		None	
Common mode Rejection	> 120dB at 120VAC		>120 dB	
Repeatability	±0.05 % FS			
The cold end temperature error	±1.5 °C		-	
Cable Resistance	max. 100 Ω		20 Ω, 2.7 Ω, for 10 pcs Ω RTD	
Diagnosis: Overflow/underflow	Support			
Circuit Break	Support			

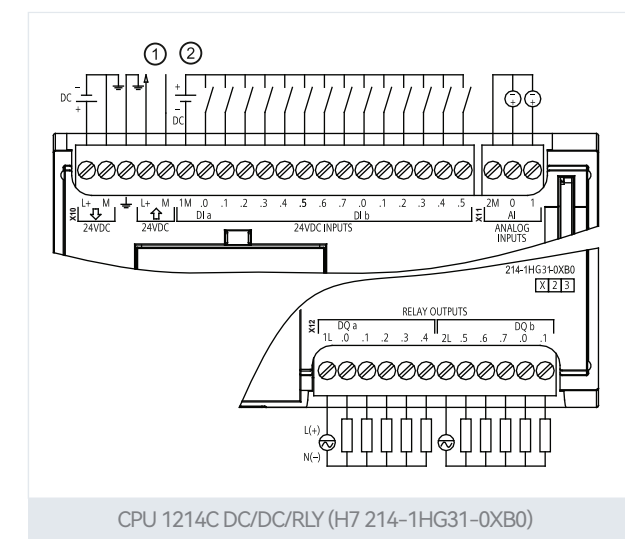
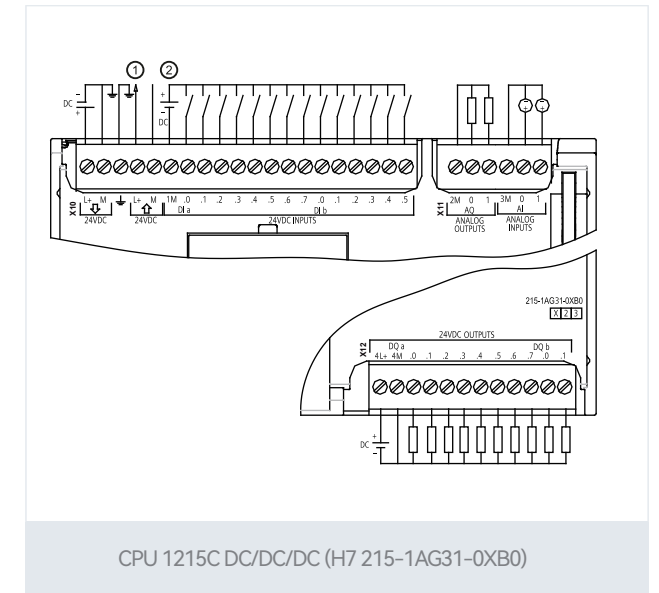
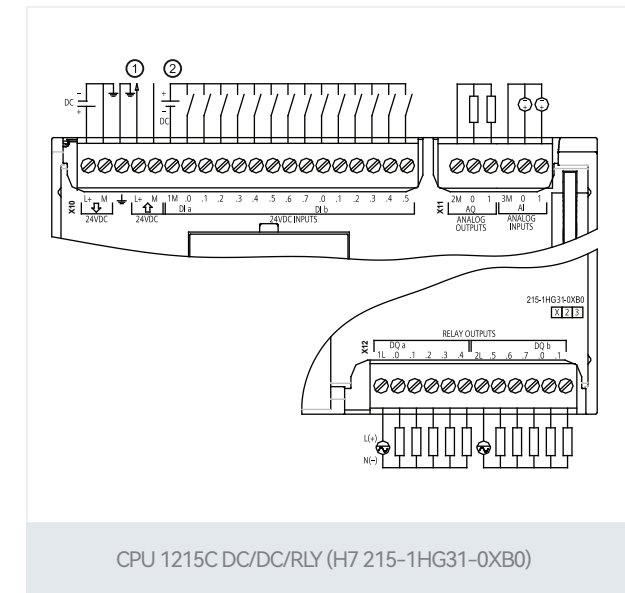

Appendix 2: H7-1200 Wiring diagram

Appendix 2: H7-1200 Wiring diagram

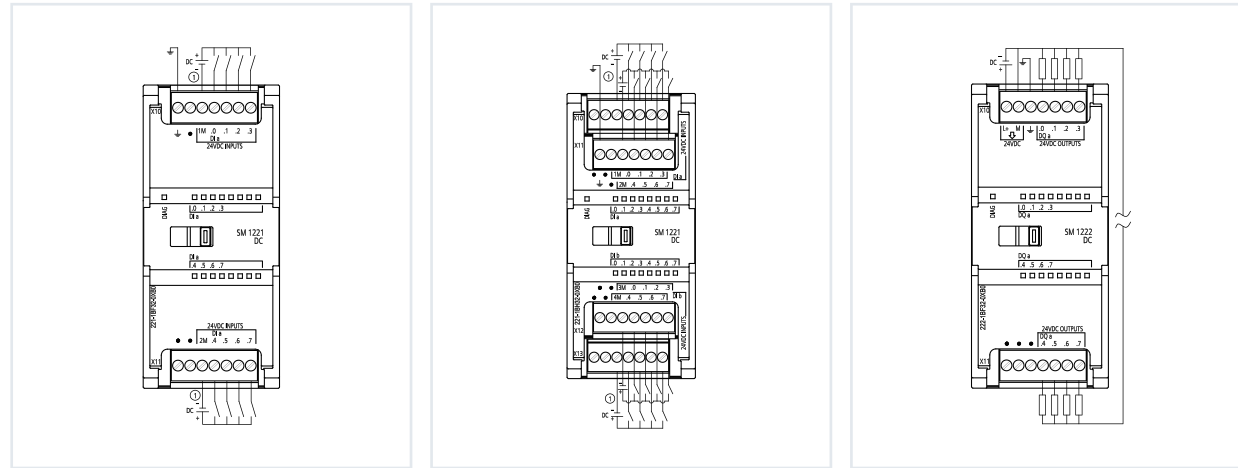

Article No.: H7-221-1BF32-0XB0
Model numbe: SM 1221 DI 8x24 V DC

Article No.: H7-221-1BH32-0XB0
Model numbe: SM 1221 DI 16x24 V DC

Article No.: H7-222-1BF32-0XB0
Model numbe: SM 1222 DQ 8x24 V DC

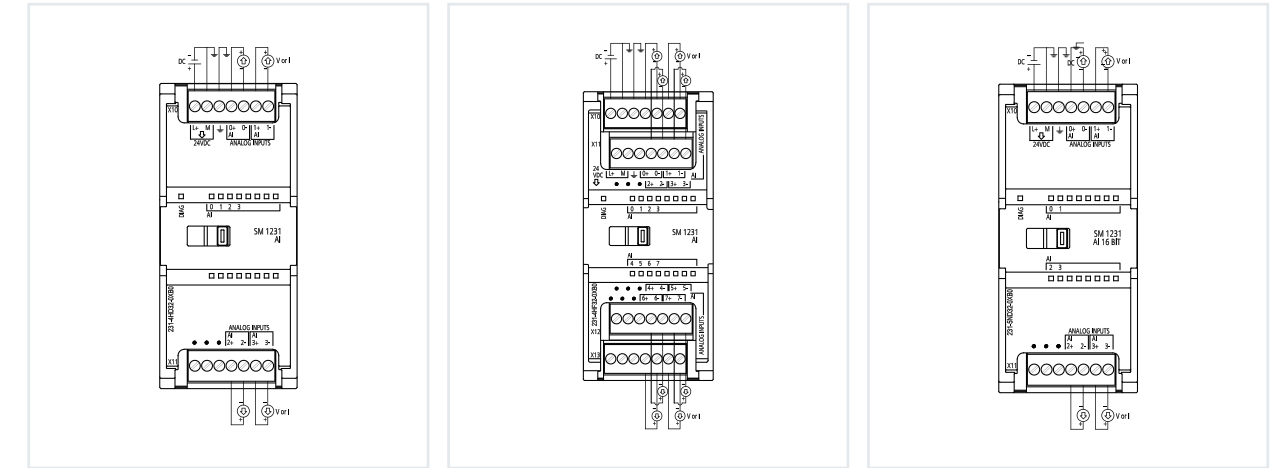

Article No.: H7-231-4HD32-0XB0
Model numbe: SM 1231 AI 4x13 bit

Article No.: H7-231-4HF32-0XB0
Model numbe: SM 1231 AI 8x13 bit

Article No.: H7-231-5ND32-0XB0
Model numbe: SM 1231 AI 4x16 bit

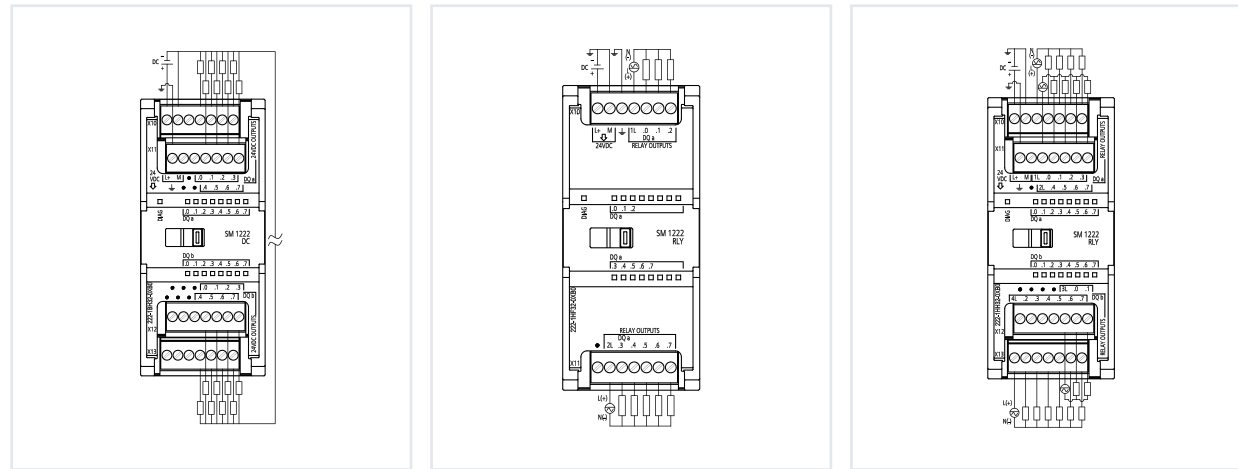

Article No.: H7-222-1BH32-0XB0
Model numbe: SM 1222 DQ 16x24 V DC

Article No.: H7-222-1HF32-0XB0
Model numbe: SM 1222 DQ 8xRLY

Article No.: H7-222-1HH32-0XB0
Model numbe: SM 1222 DQ 16xRLY

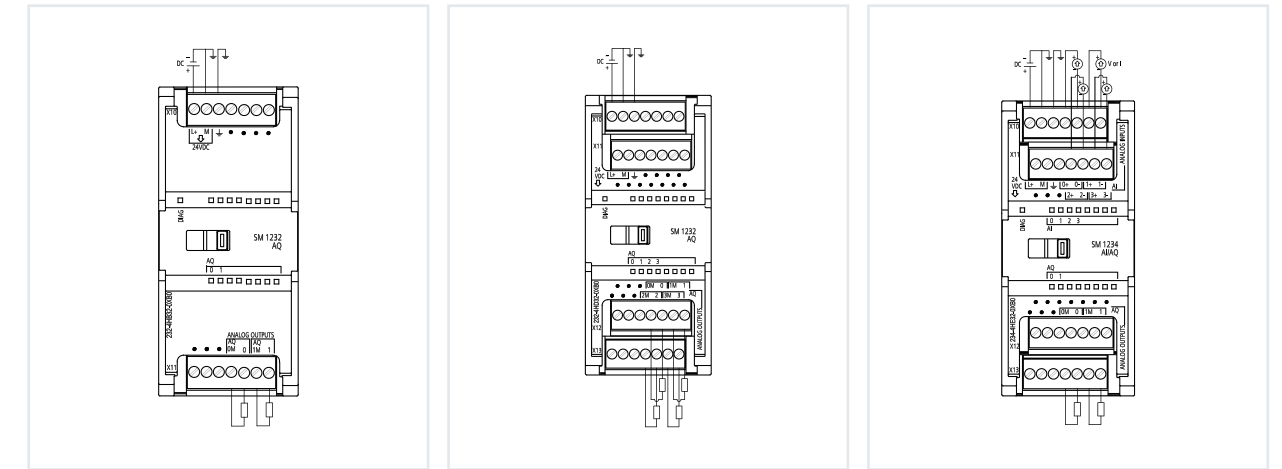

Article No.: H7-232-4HB32-0XB0
Model numbe: SM 1232 AQ 2x14-bit

Article No.: H7-232-4HD32-0XB0
Model numbe: SM 1232 AQ 4x14 bit

Article No.: H7-234-4HE32-0XB0
Model numbe: SM 1234 AI 4x13 bit

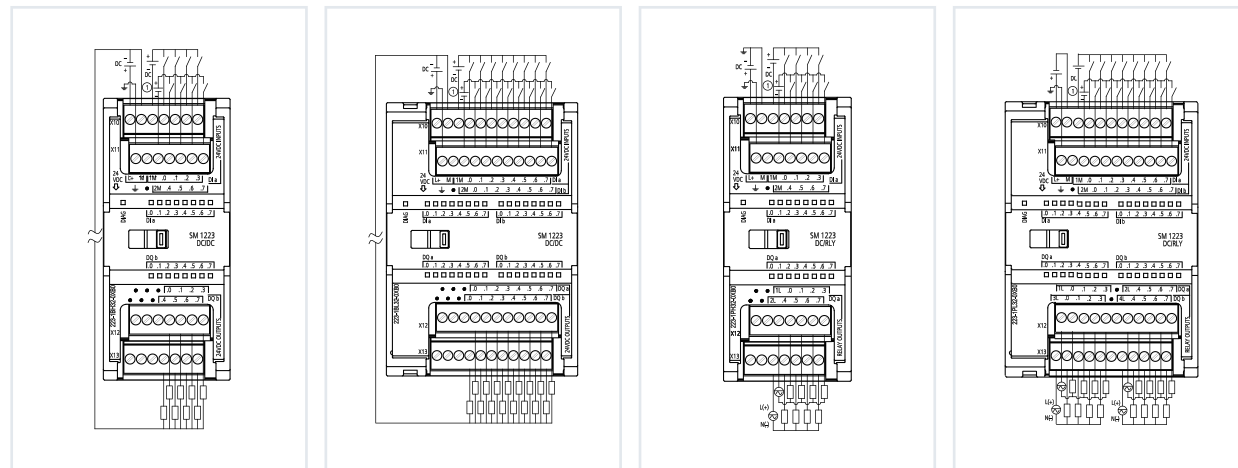

Article No.: H7-223-1BH32-0XB0
Model numbe: SM 1223 DI 8x24 V DC DQ 8x24V DC

Article No.: H7-223-1BL32-0XB0
Model numbe: SM 1223 DI 16x24 V DC DQ 16x24V DC

Article No.: H7-223-1PH32-0XB0
Model numbe: SM 1223 DI 8x24 V DC DQ 8xRLY

Article No.: H7-223-1PL32-0XB0
Model numbe: SM 1223 DI 16x24 V DC DQ 16xRLY

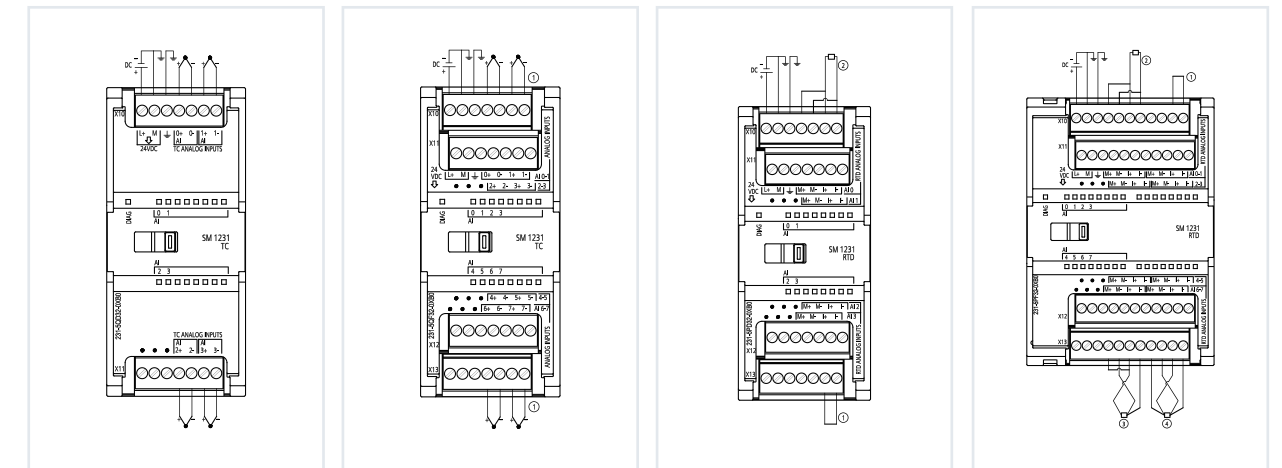

Article No.: H7-231-5QD32-0XB0
Model numbe: SM 1231 AI 4x16 bit Thermocouple

Article No.: H7-231-5QF32-0XB0
Model numbe: SM 1231 AI 8x16 bit Thermocouple

Article No.: H7-231-5PD32-0XB0
Model numbe: SM 1231 AI 4x16 bit Thermocouple

Article No.: H7-231-5PF32-0XB0
Model numbe: SM 1231 AI 8x16 bit Thermocouple

Appendix3: H7-1200 Ordering data

H7-1200 CPU

Parameters		Article No.
CPU 1215C DC/DC/RLY	24VDC, DC/DC/RLY, 14DI/10DO, 2AI/2AO	H7 215-1HG31-0XB0
CPU 1215C DC/DC/DC	24VDC, DC/DC/DC, 14DI/10DO, 2AI/2AO	H7 215-1AG31-0XB0
CPU 1214C DC/DC/RLY	24VDC, DC/DC/RLY, 14DI/10DO, 2AI	H7 214-1HG31-0XB0

H7-1200 Digital Module

Parameters		Article No.
SM1221	Digital input module DI8 x 24VDC, Drain type/source type	H7 221-1BF32-0XB0
SM1221	Digital input module DI16 x 24VDC, Drain type/source type	H7 221-1BH32-0XB0
SM1222	Digital output module DQ8x Relay type	H7 222-1HF32-0XB0
SM1222	Digital output module DQ8 x 24VDC, Transistor type	H7 222-1BF32-0XB0
SM1222	Digital output module DQ16x Relay type	H7 222-1HH32-0XB0
SM1222	Digital output module DQ16 x 24VDC, Transistor type	H7 222-1BH32-0XB0
SM1223	Digital input/output module DI8 x 24VDC Drain type/source type and DQ8 x Electric Relay, Electric Relay output	H7 223-1PH32-0XB0
SM1223	Digital input/output module DI8 x 24VDC Drain type/source type and DQ8 x 24VDC, Transistor type output	H7 223-1BH32-0XB0
SM1223	Digital input/output module DI16 x 24VDC Drain type/source type and DQ16 x Electric Relay, Electric Relay output	H7 223-1PL32-0XB0
SM1223	Digital input/output module DI16 x 24VDC Drain type/source type and DQ16 x 24VDC, Transistor type output	H7 223-1BL32-0XB0

H7-1200 Analog Module

Parameters		Article No.
SM1231	Analog input module AI4 x 13 bit, Support 0-20mA/4-20mA/±2.5V/±5V/±10V type	H7 231-4HD32-0XB0
SM1231	Analog input module AI8 x 13 bit, Support 0-20mA/4-20mA/±2.5V/±5V/±10V type	H7 231-4HF32-0XB0
SM1231	Analog input module AI4 x 16 bit, Support 0-20mA/4-20mA/±2.5V/±5V/±10V type	H7 231-5ND32-0XB0
SM1232	Analog output module AQ2 x 14 bit, Support 0-20mA/4-20mA/±10V type	H7 232-4HB32-0XB0
SM1232	Analog output module AQ4 x 14 bit, Support 0-20mA/4-20mA/±10V type	H7 232-4HD32-0XB0
SM1234	Analog I/O module AI4 + AQ2, input:13bit,Support 0-20mA/4-20mA/±2.5V/±5V/±10V type	H7 234-4HE32-0XB0

H7-1200 Temperature Module

Parameters		Article No.
SM1231	Analog input module AI4 x RTD Hot resistance	H7 231-5PD32-0XB0
SM1231	Analog input module AI4 x TC Thermocouple	H7 231-5QD32-0XB0
SM1231	Analog input module AI8 x RTD Hot resistance	H7 231-5PF32-0XB0
SM1231	Analog input module AI8 x TC Thermocouple	H7 231-5QF32-0XB0

Service and Warranty

The stage behind is the key to success, and after-sales service is the guarantee of life



3 years warranty

Within 3 years from the date of delivery, we can offer the unconditional free maintenance once occurring product quality problem.



Lifetime maintenance

We offer lifelong maintenance and repair services for the users of HUCEEN products