



## IO Product Catalog

HD200Smart  
HD200SP  
HD200M

### Shenzhen Huceen Automation Technology CO.,LTD

5F, NO.1 Building, Esun 3D Industrial Park, Zhongwu Community, Hangcheng Street, BaoAn District, Shenzhen.

+86 137 1399 0149 Caroline liu

info@huceen.com

www.huceen.com

HUCEEN is a registered trademark, and its copyright belongs to Shenzhen HUCEEN Automation Technology Co., LTD.  
The Manual information is subject to change without prior notice, please refer to the latest manual,Printed version,HUCEEN-202603



# About us

Shenzhen Huceen Automation Technology Co., Ltd. is specialized in industrial automation products R & D, production, sales and technical services, We rely on professional R & D team and years of industry technology accumulation, to supply high-quality, high-performance, highly competitive automation products and total solutions for customers.

Our company has HUCEEN brand H7 series PLC, Hpanel series HMI, HBox Internet of Things module and HCloud industrial cloud platform and other products.It provides system solutions for auto industry, electric power, chemical industry, metal-lurgy, environmental protection, water treatment, new energy, rail transportation and other industries, and it is widely used in electronic equipment, plastic machinery, packaging machinery, ceramic machinery, textile machinery, HVAC equipment, medical equipment, CNC equipment and many other industries.

We adhere to the business philosophy of integrity and truth-seeking. We build on the industrial automation with our own intellectual property rights, and promote the competitiveness and profitability of our customers. We work with our customers to create a win-win situation, realize enterprise value and customer value grow together.

## Mission

To help customers become industry leaders

## Vision

To become a respected and global supplier of industrial automation products and solutions

## Value

Integrity, specialty, innovation, sharing

## Operation philosophy

Improve customers competitiveness continuously , we not only provide excellent products and services, but also supply customers with more industry knowledge and more professional technical solutions.

**700K**  
Quantity of shipment

**30+**  
Cooperated Listed Company

**80+**  
Sales and service network



National High-tech Enterprise



30+ Technology patents

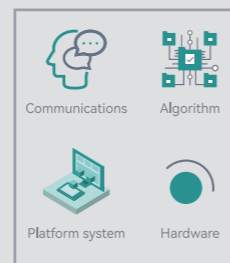

4 core technologies



# CATALOG

## Huceen product system

**PLC**

200Smart

- E7 200Smart
- E5 200Smart
- E3 200Smart

H7-1200

Distributed Remote I/O



**Internet of Things**

H-Box

Smart Box

IoT PLC E7 200 Smart

HCloud industrial cloud platform

**HMI**

Hpanel 7-inch

Hpanel 10-inch

### 1、 Overview

About Huceen	01
Product Portfolio	03

### 2、 Distributed Remote I/O Series

Introduction to the Features of Distributed Remote I/O	05
--	----

### 3、 Introduction to HD 200Smart Series Products

Features of HD 200Smart Series Products	06
Technical Specifications of HD 200Smart Series Interface Module IM155	07
Technical Specifications of HD 200Smart Series Interface Module IM60	08
Technical Specifications of HD 200Smart Series Expansion Modules E-Series Modules	
Technical Specifications of Digital Input/Output Modules	10
Technical Specifications of Analog Input/Output Modules	13
Technical Specifications of Thermocouple Temperature Measurement Modules	16
Technical Specifications of Resistance Temperature Detector Measurement Modules	18

### 4、 Introduction to HD 200SP Series Products

Features of HD 200SP Series Products	19
Technical Specifications of HD 200SP Series Profinet Interface Modules	20
Technical Specifications of HD 200SP Series Expansion Modules	
Technical Specifications of Digital Input/Output Modules	21
Technical Specifications of Analog Input/Output Modules	23

### 5、 Introduction to HD 200M Series Products

Features of HD 200M Series Products	28
Technical Specifications of HD 200M Series Interface Module IM153	30
Technical Specifications of HD 200M Series Expansion Modules H7-300 Series Modules	
Technical Specifications of Digital Input/Output Modules	31
Technical Specifications of Analog Input/Output Modules	34

### 6、 Appendix

Appendix 1: Wiring Diagram of HD 200Smart Series Products	37
Appendix 2: Wiring Diagram of HD 200SP Series Products	40
Appendix 3: Wiring Diagram of HD 200M Series Products	54
Appendix 4: Ordering Data	55

### 7、 Service Commitment

# Distributed remote I/O features

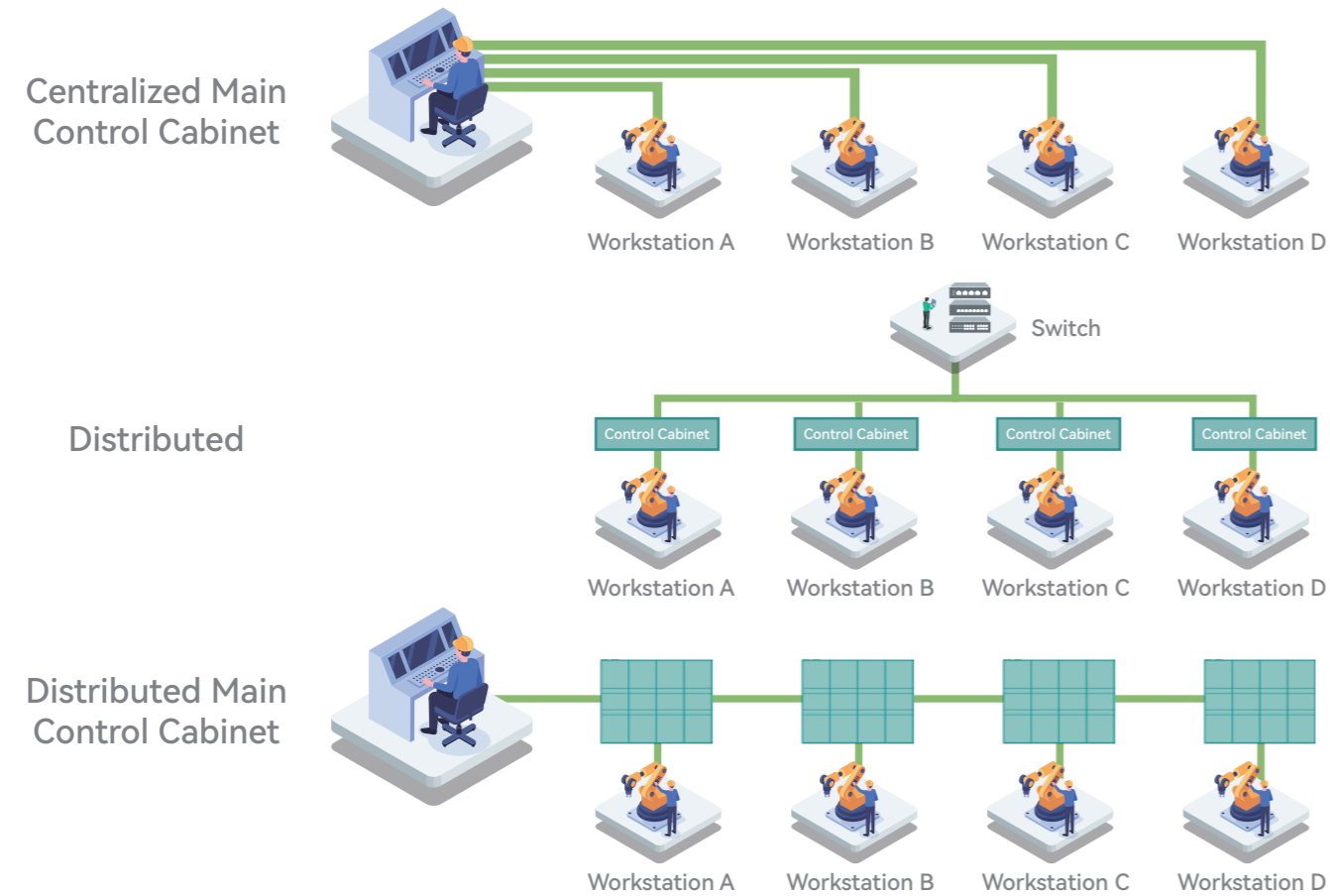

## Significant Simplification of Wiring and Reduction of Overall Costs

Distributed remote I/O can be installed close to the equipment, requiring only one communication line to the control cabinet, reducing cable usage and construction time. In large-space environments such as automotive welding lines and chemical workshops, a single production line can reduce cable length by more than 50%, avoiding the complexity of cable tray wiring.

## Strong Expansion Capability

Remote I/O can be cascaded in a "master station + slave station" configuration. The Huichen H7-1200 series CPU supports up to 4096 I/O points, meeting the control requirements of large workshops and distributed equipment.

## Flexible Adjustment of Production Workstations

Production line changes and equipment relocations are common in industrial production. Distributed remote I/O allows for rapid adaptation without requiring modifications to the main controller cabinet.

## Accurate Fault Diagnosis and Reduced Downtime

Huceen modules come with built-in LED indicators (for power, communication, and channel status). Combined with TIA Portal software, fault codes (e.g., "channel short circuit," "communication packet loss") can be viewed directly, reducing fault location time to within 5 minutes.

# Features of the HD 200Smart Series Distributed Remote I/O

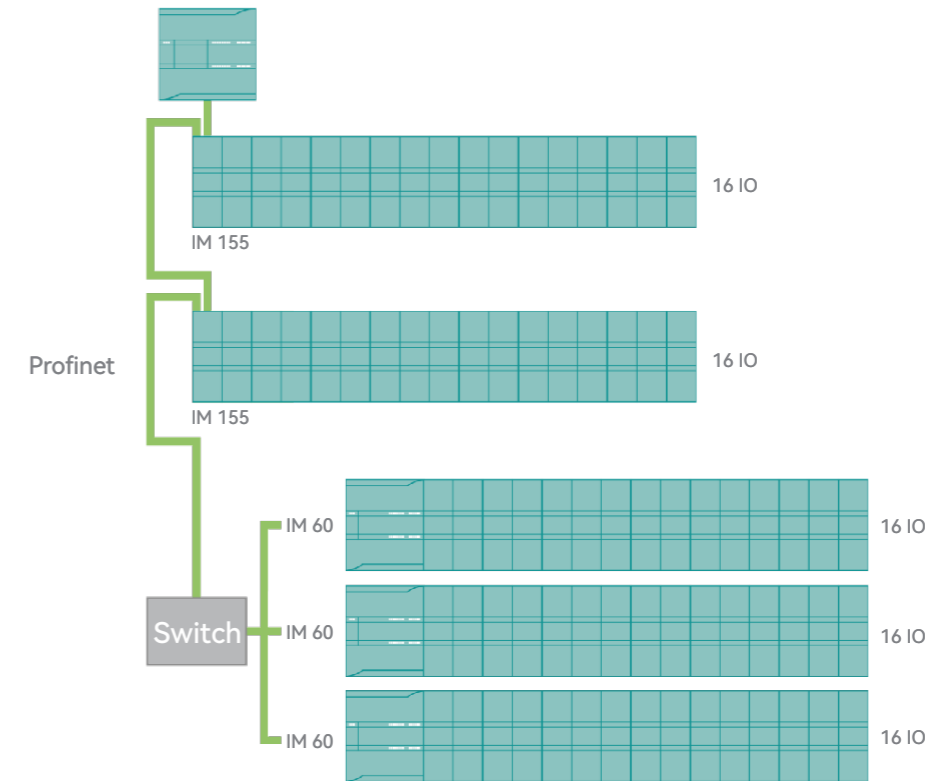

## Functional Features

- Feature 1** Perfect compatibility, easy operation, and support for TIA Portal software configuration;
- Feature 2** Supports expansion of 16 E series modules on the right side. The modules have filtering, channel freezing, and overflow alarm functions
- Feature 3** The IM155 interface module has 2 RJ45 network ports, supporting star, tree, and ring topologies;
- Feature 4** The IM60 interface module has 60 digital input/output points, 1 RJ45 network port, and 1 RS485 interface
- Feature 5** Supports Profinet fieldbus and allows flexible layout of remote distributed I/O systems

# HD 200Smart Series Remote I/O Interface Modules - IM 155

Model No.	IM 155
Order No.	E 288-4PN01-0AA1
Picture	
Product Description	Based on PROFINET slave station interface module of Ethernet, can be expandable to 16 smart modules
Standard	
Dimension (W×H×D)	47×100×81mm
Power Input Voltage	20.4-28.8VDC
Power Input Current	max.0.8A
Power Consumption	max.20W
PROFINET Communication Parameters	
Communication Ports	2 RJ45 ports
Electrical Type	RJ45 (Not support polarity adaptation)
Transmission Rate	100 Mbps, full duplex
Supported Ethernet Service	ping arp Network Diagnosis (SNMP) /MIB-2 LLDP
Minimum Cycle Time	5ms
Third-party PROFINET Master Station	Support
The communication distance between slave station is the longest	100m (100BASE-TX)
Topological Structure	Support star, tree, line and ring topology structure
Hardware Configuration Function	
Importing File Type	PROFINET GSD file, XML format
Expansion Capability	Support 16 Smart Modules Expansion Expansion module can add digital module, analog module and temperature module
Isolation and Protection	
Interface Isolation	transformer isolation of RJ45 communication port
Power Supply Protection	The power supply terminal provides reverse connection protection and surge absorption function.
Function Introduction	
Overview	IM155 communication interface module is distributed I/O module developed by Huceen Automation for system integrated customers; It has high-speed Ethernet communication, support Profinet slave station communication protocol, and can be mounted under Profinet master station equipment; Meanwhile, a single module can be expanded to 16 smart modules
Product Features	1. High-speed Ethernet communication; 2. Support Profinet master & slave station communication protocol; 3. Flexible application and can expand smart family module.



# HD 200Smart Series Remote I/O Interface Modules - IM 60

Model	IM 60
Order Number	E 288-4RM60-0AA1
Picture	
General Specifications	
Dimensions (W×H×D, mm)	175 x 100 x 81
Power Consumption	20 W MAX
Available Current (EM Bus)	Max. 1400 mA (5 V DC)
Available Current (24 V DC Output)	Max. 300 mA (Sensor Power)
Digital Input Current Consumption (24 V DC)	4 mA per input point
Onboard Digital I/O	36 inputs / 24 outputs
Supported Expansion Module Quantity	Up to 16 modules
Supported Expansion Module Series	E Series modules
Firmware Upgrade Method	Supports upgrade via Ethernet, supports upgrade via TF card
Communication Standards	
Number of Ports	PROFINET (LAN): 1 RS485 (COM) : 1
Data Transfer Rate	PROFINET (LAN): 10/100 Mb/s RS485 (COM): 1.2 Kbps to 115.2 Kbps
Isolation (External Signals vs. PLC Logic Side)	PROFINET (LAN): Transformer isolated, 1500 V AC RS485: Not isolated
PROFINET IO Device	Supported
PROFINET Cycle Time	4 ms to 512 ms
PN IO Data Length	I/O data length up to 1024 bytes
RS485 Supported Protocols	Modbus-RTU Master/Slave, supports up to 8 read/write commands Each command can read/write up to 16 bytes
RS485 Data Transfer Rate	1200bps, 2400bps, 4800bps, 9.6Kbps, 19.2Kbps, 38.4Kbps, 57.6Kbps, 115.2Kbps
RS485 Features	
Parity Bit	None, Odd, Even
Stop Bit	1, 2
Data Bit	7, 8
Power Supply	
Voltage Range	20.4—28.8V DC
Input Current (Maximum Load)	Without attached modules: 220 mA With 6 modules and sensor output 300 mA: 710 mA
Hold Time (Power-off)	100 ms at 24 V DC
Sensor Power	
Voltage Range	20.4 to 28.8 V DC
Rated Output Current (Maximum)	300 mA





# HD 200Smart Series Remote I/O Interface Modules - IM 60

Model	IM 60
Order Number	E 288-4RM60-0AA1
<b>Digital Inputs</b>	
Number of Inputs	36
Type	Sink/Source type (IEC 1 class sink type, except I0.0 to I0.3)
Rated Voltage	Rated 24 V DC at 4 mA
Permissible Continuous Voltage	Max. ±60 V DC
Surge Voltage	200 V DC, 0.5 s
Logic 1 Signal (Min.)	Channels 0 to 3: 4 V DC at 8 mA Other input points: 15 V DC at 2.5 mA
Logic 0 Signal (Max.)	Channels 0 to 3: 1 V DC at 1 mA Other input points: 5 V DC at 1 mA
Isolation (Field Side vs. Logic Side)	707 V DC, 1 min
Isolation Group	1
Filter Time	Selectable per channel: 0, 6.4 ms, 12.8 ms
Number of Simultaneously Active Inputs	36
Cable Length (Max., meters)	Shielded: 500 m, Unshielded: 300 m
<b>Digital Outputs</b>	
Number of Outputs	24
Type	Solid-state - MOSFET (Source type)
Voltage Range	20.4 to 28.8 V DC
Logic 1 Signal at Max. Current	Min. 20 V DC
Logic 0 Signal with 10 k $\Omega$ Load	Max. 0.1 V DC
Rated Current per Point (Max.)	0.5 A
Rated Current per Common Terminal (Max.)	6 A
Lamp Load	5 W
On-State Resistance	Max. 0.6 $\Omega$
Leakage Current per Point	Max. 10 $\mu$ A
Surge Current	8 A, max. duration 100 ms
Isolation (Field Side vs. Logic Side)	500 V AC, 1 min
Isolation Group	3
Switching Delay	OFF to ON max. 50 $\mu$ s ON to OFF max. 200 $\mu$ s
Output Behavior in STOP Mode	Output off / hold last value / output = 1
Number of Simultaneously Active Outputs	24
Cable Length (Max., meters)	Shielded: 500 m, Unshielded: 150 m





# Digital input module

Model No.	EM DE08	EM DE16
Order No.	E 288-2DE08-0AA1	E 288-2DE16-0AA1
Picture		
Product Description	8-digital input, 24VDC	16-digital input, 24VDC
<b>Standard</b>		
Dimension (W×H×D)	47×100×81mm	
Power Consumption	1.5W	2.3W
Current Consumption (SM bus)	120mA	130mA
Current Consumption (24V DC)	4mA for each input point used	
<b>Digital Input</b>		
Number of Inputs	8	16
Input Type	PNP/NPN (IEC type 1 sinking)	
Rated Voltage	24V DC when the current is 4mA, Rated Value	
Allowable Continuous Voltage	Max 30V DC	
Surge Voltage(Max)	35V DC, lasting 0.5s	
Logic 1 Signal (Min)	it is 15V DC when the current is 2.5mA	
Logic 0 Signal (Max)	it is 5V DC when the current is 1mA	
Optical Isolation (field side and logic side)	500V AC, lasting 1.0min	
Isolation Group	2	4
Filter Time	-	-
Number of inputs that connect at the same time	8	16
.55° (horizontal)	All	
.45° (vertical)	All	
Cable Length(Max)		
.Shield	500M	
.Unshielded	300M	





## Digital output module

Model No.	EM DR08	EM DT08	EM QR16	EM QT16
Order No.	E 288-2DR08-0AA1	E 288-2DT08-0AA1	E 288-2QR16-0AA1	E 288-2QT16-0AA1
Picture				
Product Description	8-digital output, relay	8-digital output, transistor	16-digital output, relay	16-digital output, transistor
Standard	47x100x81mm			
Dimension (WxHxD)	47x100x81mm			
Power Consumption	4.5W	1.5W	4.5W	1.7W
Current Consumption (SM bus)	120mA	120mA	110mA	120mA
Current Consumption (24V DC)	9mA for each relay coil used	–	9mA for each relay coil used	–
Digital Output				
Number of Outputs	8		16	
Output Type	Relay	Solid-MOSFET (source type)	Relay	Solid-MOSFET (source type)
Voltage Range	5-30V DC or 5-250V AC	20.4-28.8V DC	5-30V DC or 5-250V AC	20.4-28.8V DC
Surge Current (Max)	7A when power on	8A, lasting 100ms	7A when power on	8A, lasting 100ms
Rated Current per point (Max)	2.0A	0.75A	2.0A	0.75A
Switching Delay	Up to 10ms	from the disconnection to connection(Max): 50µs; from the connection to disconnection(Max): 200µs	Up to 10ms	from the disconnection to connection(Max): 50µs; from the connection to disconnection(Max): 200µs
Optical Isolation(field side and logic side)	1500V AC, lasting 1.0min(coil and contact), None(coil and logic side)	500V AC, lasting 1.0min)	1500V AC, lasting 1.0min(coil and contact), None(coil and logic side)	500V AC, lasting 1.0min
Isolation Group	2		4	
Output Status in STOP Mode	previous value or replacement value (default is 0)			
Contact Lifetime				
.Non-loaded	10,000,000 break / close cycles	–	10,000,000 break / close cycles	–
.Rated load	100,000 break / close cycles	–	100,000 break / close cycles	–
Number of Inputs that connect at the same time	8		16	
.55° (horizontal)	All			
.45° (vertical)	All			
Cable Length(Max)				
.Shield	500M			
.Unshielded	150M			





## Digital input/output module

Model No.	EM DR16	EM DT16	EM DR32	EM DT32
Order No.	E 288-2DR16-0AA1	E 288-2DT16-0AA1	E 288-2DR32-0AA1	E 288-2DT32-0AA1
Picture				
Product Description	8-digital input/ 8-digital output, relay	8-digital input/ 8-digital output, transistor	16-digital input/ 16-digital output, relay	16-digital input/ 16-digital output, transistor
Standard	47x100x81mm			
Dimension (WxHxD)	47x100x81mm		72x100x81mm	
Power Consumption	5.5W	2.5W	10W	4.5W
Current Consumption (SM bus)	145mA	145mA	180mA	180mA
Current Consumption (24V DC)	4mA for each input point used, each relay coil used is 11mA	4mA for each input point used	4mA for each input point used, each relay coil used is 11mA	4mA for each input point used
Digital Input				
Number of Outputs	8		16	
Input Type	PNP/NPN (IEC type 1 sinking)			
Surge Voltage(Max)	35V DC, lasting 0.5s			
Logic 1 Signal (Min)	15V DC			
Logic 0 Signal (Max)	5V DC			
Optical Isolation (field side and logic side)	500V AC, lasting 1min			
Isolation Group	2			
Filter Time	0.2,0.4,0.8,1.6, 3.2, 6.4,12.8ms ( optional, 4 inputs form one group )			
Number of Inputs that connect at the same time	8		16	
Cable Length(M)	500M(shield), 150M(unshielded)			
Digital Output				
Number of Outputs	8		16	
Output Type	Relay	Solid-MOSFET (source type)	Relay	Solid-MOSFET (source type)
Voltage Range	5~30V DC or 5~250V AC	20.4~28.8V DC	5~30V DC or 5~250V AC	20.4~28.8V DC
Surge Current	7A when power on	8A, max. lasting 100ms	7A when power on	8A, max. lasting 100ms
Rated Current per point (Max)	2.0A	0.75A	2.0A	0.75A
Switching Delay	from the disconnection to connection(Max): 50µs; from the connection to disconnection(Max): 200µs	Up to 10ms	from the disconnection to connection(Max): 50µs; from the connection to disconnection(Max): 200µs	Up to 10ms
Optical Isolation(field side and logic side)	1500V AC, lasting 1.0min (coil and contact), None(coil and logic side)	500V AC, lasting 1.0min	1500V AC, lasting 1.0min (coil and contact), None(coil and logic side)	500V AC, lasting 1.0min
Isolation Group	2		4	
Output Status in STOP Mode	previous value or replacement value (default is 0)			
Number of Inputs that connect at the same time	8		16	
.55° (horizontal)	All			
.45° (vertical)	All			
Cable Length (M)				
.Shield	500M			
.Unshielded	150M			





## Analog input module

Model No.	EM AE04		EM AE08	
Order No.	E 288-3AE04-0AA0	E 288-3AE04-0AA1	E 288-3AE08-0AA0	E 288-3AE08-0AA1
Picture				
Product Description	Bipolar, 4-channel analog input, resolution 12 bits, full channel support current/voltage input	Unipolarity, 4-channel analog input, resolution 12 bits, full channel support current/voltage input	Bipolar, 8-channel analog input, resolution 12 bits, full channel support current/voltage input	Unipolarity, 8-channel analog input, resolution 12 bits, full channel support current/voltage input
Standard				
Dimension (W×H×D)	47×100×81mm			
Power Consumption	1W			
Current Consumption (SM bus)	90mA			
Current Consumption (24V DC)	20mA			
Analog Input				
Number of Inputs	4		8	
Input Type	voltage or current (differential): 2 can be selected as a group range	Voltage or current (single ended): 2 can be selected as a group	voltage or current (differential): 2 can be selected as a group range	Voltage or current (single ended): 2 can be selected as a group
Input Range				
Electric Current	0~20mA			
Supply Voltage	±2.5V, ±5V, ±10V	0-10V	±2.5V, ±5V, ±10V	0-10V
Data Word Format				
.Unipolarity	0~+27648	0~+27648	0~+27648	0~+27648
.Bipolar	±27648	0~+27648	±27648	0~+27648
Max. Voltage Resistance	±35V			
Max. Current Resistance	±40mA			
Smoothness	None, weak, medium or strong			
Noise Supression	400,60,50 or 10Hz	50 or 10Hz	400,60,50 or 10Hz	50Hz
Resolution				
Voltage Mode	12 bits + symbol bits	12 bits	12 bits + symbol bits	12 bits
Current Mode	12 bits			
Isolation (field side and logic side)	1500V AC			
Precision (25°C/0-55°C)				
.Voltage Mode	full range ±0.1%/±0.2%	full range ±0.3%/±0.5%	full range ±0.1%/±0.2%	full range ±0.3%/±0.5%
.Current Mode	full range ±0.2%/±0.3%	full range ±0.4%/±0.6%	full range ±0.2%/±0.3%	full range ±0.2%/±0.3%
Analog to digital Conversion Time	625 μs (400Hz inhibited)	500ms(50HZ)	625 μs (400Hz inhibited)	500ms(50HZ)
Common mode Rejection	40dB, DC to 60HZ	—	40dB, DC to 60HZ	—
Working Signal Range	signal plus common mode voltage ≤12V	—	signal plus common mode voltage ≤12V	—
Diagnosis	Overflow/ underflow, 24V DC low voltage		Overflow/ underflow, 24V DC low voltage	
Cable Length (M)	100m, shielded twisted pair		100m, shielded twisted pair	

## Analog output module

Model No.	EM AQ02		EM AQ04	
Order No.	E 288-3AQ02-0AA0	E 288-3AQ02-0AA1	E 288-3AQ04-0AA0	E 288-3AQ04-0AA1
Picture				
Product Description	Bipolar, 2-channel analog output, full-channel support current/voltage output	Unipolarity, 2-channel analog output, full-channel support current/voltage output	Bipolar, 4-channel analog output, full-channel support current/voltage output	Unipolarity, 4-channel analog output, full-channel support current/voltage output
Standard				
Dimension (W×H×D)	47×100×81mm			
Power Consumption	1.5W		2.1W	
Current Consumption (SM bus)	90mA			
Current Consumption (24V DC)	50mA		70mA	
Analog Output				
Number of Outputs	2		4	
Output Type	Voltage or current			
Output Range	—			
.Current Output	0-20mA			
.Voltage Output	±10V	0-10V	±10V	0-10V
Data Word Format	—			
.Current Output	0-27648			
.Voltage Output	±27648	0-27648	±27648	0-27648
Resolution				
Voltage Mode	11 bits + symbol bits	11 bits	11 bits + symbol bits	11 bits
Current Mode	11bits			
Isolation (field side and logic side)	500V AC			
Precision				
.Typical, 25°	full range ±0.5%			
.Worst, 0° to 55°	full range ±1.0%			
Output Status in STOP Mode	previous value or replacement value (default is 0)			
Diagnosis				
.Voltage Mode	Overflow/ underflow, short circuit to ground, 24V DC low voltage	Overflow/ underflow, 24V DC low voltage	Overflow/ underflow, short circuit to ground, 24V DC low voltage	Overflow/ underflow, 24V DC low voltage
.Current Mode	Overflow/ underflow, wire break, 24V DC low voltage	Overflow/ underflow, 24V DC low voltage	Overflow/ underflow, wire break, 24V DC low voltage	Overflow/ underflow, 24V DC low voltage
Cable Length (M)	100m, shielded twisted pair			

## Analog input/output module

Model No.	EM AM03		EM AM06	
Order No.	E 288-3AM03-0AA0	E 288-3AM03-0AA1	E 288-3AM06-0AA0	E 288-3AM06-0AA1
Picture				
Product Description	Bipolar, 2-channel analog input/ 1-channel analog output, full-channel support current/voltage type	Unipolarity, 2-channel analog input/ 1-channel analog output, full-channel support current/voltage type	Bipolar, 4-channel analog input/ 2-channel analog output, full-channel support current/voltage type	Unipolarity, 4-channel analog input/ 2-channel analog output, full-channel support current/voltage type
Standard	47×100×81mm			
Dimension (W×H×D)	11W		2.0W	
Power Consumption	90mA			
Current Consumption (SM bus)	30mA		60mA	
Available Current (24V DC)	Analog Input			
Number of Inputs	2		4	
Input Type	voltage or current (differential): 2 can be selected as a group range	Voltage or current (single ended): 2 can be selected as a group	voltage or current (differential): 2 can be selected as a group range	Voltage or current (single ended): 2 can be selected as a group
Input Range	0~20mA			
.Electric Current	±2.5V, ±5V, ±10V			
.Supply Voltage	±2.5V, ±5V, ±10V	0-10V	±2.5V, ±5V, ±10V	0-10V
Resolution	12 bits			
Voltage Mode	12 bits + symbol bits	12 bits	12 bits + symbol bits	12 bits
Current Mode	12 bits			
Precision	12 bits			
.Voltage Mode	±0.2%/±0.3% full range	±0.3%/±0.5% full range	±0.2%/±0.3% full range	±0.3%/±0.5% full range
.Current Mode	±0.2%/±0.3% full range	±0.4%/±0.6% full range	±0.2%/±0.3% full range	±0.4%/±0.6% full range
Analog to digital Conversion Time	625µs(400Hz inhibited)	50 or 10Hz	625µs(400Hz inhibited)	50 or 10Hz
Number of Outputs	1		2	
Output Type	Voltage/current			
Output Range	-			
.Current Output	0-20mA			
.Voltage Output	±10V	0-10V	±10V	0-10V
Resolution	11 bits			
Voltage Mode	11 bits + symbol bits	11 bits	11 bits + symbol bits	11 bits
Current Mode	11 bits			
Isolation (field side and logic side)	500V AC			
Precision	full range ±0.5%			
.Typical, 25°	full range ±1.0%			
.Worst, 0° to 55°	Diagnosis			
Diagnosis	Overflow/ underflow, short circuit to ground, 24V DC low voltage			
.Voltage Mode	Overflow/ underflow, short circuit to ground, 24V DC low voltage	Overflow/ underflow, 24V DC low voltage	Overflow/ underflow, short circuit to ground, 24V DC low voltage	Overflow/ underflow, 24V DC low voltage
.Current Mode	Overflow/ underflow, short circuit, 24V DC low voltage	Overflow/ underflow, 24V DC low voltage	Overflow/ underflow, short circuit, 24V DC low voltage	Overflow/ underflow, 24V DC low voltage
Cable Length (M)	100m, shielded twisted pair			

## Thermocouple module



Model No.	EM AT04
Order No.	E 288-3AT04-0AA1
Picture	
Product Description	4-channel thermocouple module
Standard	47×100×81mm
Dimension (W×H×D)	1.5W
Power Consumption	120mA
Current Consumption (SM bus)	40mA
Current Consumption (24V DC)	Analog Input
Number of Inputs	4
Range	Please refer to the thermocouple selection table
Rated Range (Data word)	
Overshoot/Undershoot Range (Data word)	
Overflow/underflow (Data word)	Measuring Principle
Measuring Principle	Sigma-Delta
Resolution	0.1°C / 0.1°F
.Temperature	15 bits+ symbol bits
.Voltage	±60V
Max. Voltage Resistance	500V AC
Isolation	500V AC
.Field side and logic side	500V AC
.Field side and 24V DC side	500V AC
.24V DC side and Logic side	Support
Channel to channel Isolation	>120dB at 120V AC
Common mode Rejection	±0.05%FS
Repeatability	±1.5°C
The cold end temperature error	100Ω
Cable Loop Resistance (Max)	Overflow/ underflow, circuit break, 24V DC low voltage
Diagnosis	100m, shielded twisted pair
Cable Length	400Hz(2.5ms) 60Hz(16.6ms) 50Hz(20ms) 10Hz(100ms)
Rejection Frequency Selection	

Remark: when 400Hz inhibition is selected, the integration time should be 10ms to ensure the resolution and precision of module. Meanwhile this selection will also suppress noise at frequency of 100Hz and 200Hz. It is recommended to use an integration time of 100ms while measuring thermocouple. Using smaller integration time will increase repeatability error of temperature reading.

## Thermocouple module

Model No.	EM AT08
Order No.	E 288-3AT08-OAA1
Picture	
Product Description	8-channel thermocouple module, resolution 16 bits
Standard	
Dimension (W×H×D)	47×100×81mm
Power Consumption	1.5W
Current Consumption (SM bus)	50mA
Current Consumption (24V DC)	40mA
Analog Input	
Number of Inputs	8
Input Type	TC
Input Range	
.Type	EJKNRST
.Voltage Range	±80mV
Data Word Format	Voltage: -27648 to +27648
Measuring Principle	Sigma-Delta
Resolution	
.Temperature	0.1°C / 0.1°F
.Voltage	15 bits+ symbol bits
.Resistance	—
Max. Voltage Resistance	±60V
Isolation	
.Field side and logic side	500V AC
.Field side and 24V DC side	500V AC
.24V DC side and Logic side	500V AC
Channel to channel Isolation	Support
Common mode Rejection	120V AC, >120dB
Repeatability	±0.05%FS
The cold end temperature error	±1.5°C
Cable Loop Resistance (Max)	100Ω
Cable Length	100m

## RTD modules

Model No.	EM AR02	EM AR04
Order No.	E 288-3AR02-OAA1	E 288-3AR04-OAA1
Picture		
Product Description	2-channel RTD module, resolution 16 bits	4-channel RTD module, resolution 16 bits
Standard		
Dimension (W×H×D)	47×100×81mm	
Power Consumption	1.5W	
Current Consumption (SM bus)	120mA	
Current Consumption (24V DC)	40mA	
Analog Input		
Number of Inputs	2	4
Range Rated Range (Data word)	Please refer to RTD sensor selection table	
Overshoot/Undershoot Range (Data word)	Please refer to RTD sensor selection table	
Overflow/underflow (Data word)	Please refer to RTD sensor selection table	
Measuring Principle	Sigma-Delta	
Resolution		
.Temperature	0.1°C / 0.1°F	
.Voltage	15 bits+ symbol bits	
Max. Voltage Resistance	±60V	
Isolation		
.Field side and logic side	500V AC	
.Field side and 24V DC side	500V AC	
.24V DC side and Logic side	500V AC	
Channel to channel Isolation	Support	
Common mode Rejection	>120dB	
Repeatability	0.05%FS	
Max Power Consumption of the Sensor r	0.5mW	
Cable Loop Resistance (Max)	20Ω, for Cu10, the maximum is 2.7Ω	
Diagnosis	Overflow/ underflow, circuit break, 24V DC low voltage	
Cable Length	100m, shielded twisted pair	
Rejection Frequency Selection	400Hz(2.5ms) 60Hz(16.6ms) 50Hz(20ms) 10Hz(100ms)	

Remark: When selecting 400Hz filter, and maintaining the resolution and accuracy of the module, the integration time should be 10ms. Meanwhile this selection will also suppress noise at frequency of 100Hz and 200Hz.

# Features of the HD 200SP Series Distributed Remote I/O

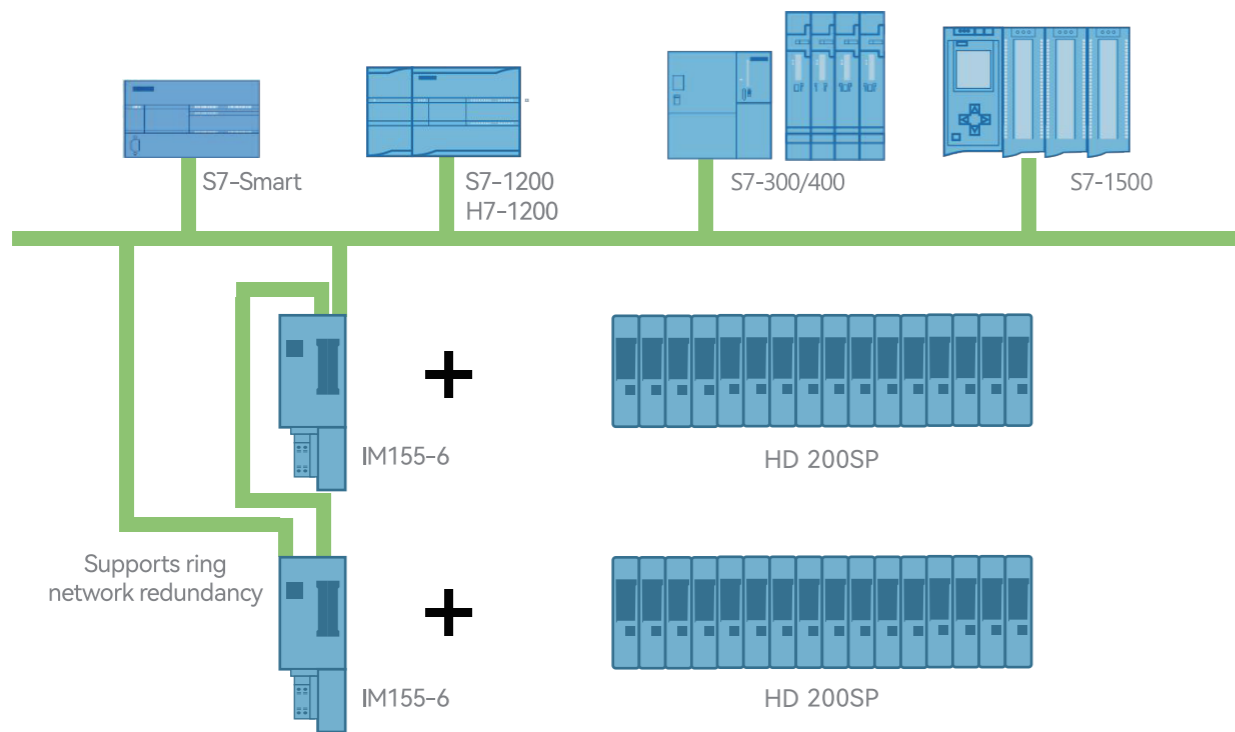

High Flexibility and Modular I/O System: Enables I/O data exchange via interface modules.

Supports PROFINET Fieldbus.

# PN Interface Module Technical Specifications

Model	155-6 Standard Module
Order No.	P7 155-6AA01-0BN0
Picture	
Product Description	IM155-6 PN ST Interface Module Integrated with 2 RJ45 ports
Standard	
Supply Voltage	Rated Value (DC): 24 V Permissible Lower Limit (DC): 19.2 V Permissible Upper Limit (DC): 28.8 V
Reverse Polarity Protection	√
Power Loss, Typ.	4.5 W
Maximum Current Consumption	550 mA
Maximum Power Consumption for Backplane Bus	4.5 W
Number of PROFINET Ports	1; 2 Ports (Switch)
PROFINET Interface	2 X RJ45
Environmental Conditions	
STEP 7 TIA Port, Configurable	V14
STEP 7 Configurable / Integrated	V5.5 SP4 and higher
STEP 7 Configuration Model	155-6AU01-0BN0
PROFINET Version GSD or higher	V2.3 / -
Number of Supported Modules	16
Module Address Space	Maximum 256 bytes
Station Address Space	Maximum 512 bytes
Profisafe Fail-safe	\
PROFINET Standard	
RT:	Supported
IRT:	\
PROFINET Shared Devices:	
Supports Fastest PN Bus Scanning Cycle	8 ms
Ring Redundancy (MRP)	Supported
Diagnostic Functions:	Supported
Status Display	Supported
Alarm	Supported
Diagnostic Function	Supported
Interrupt	Supported
Status Display:	
• RUN LED	Yes; Green LED
• ERROR LED	Yes; Red LED
• MAINT LED	Yes; Yellow LED
• Power Supply Voltage Monitoring (PWR-LED)	Yes; Green PWR-LED
• LINK TX/RX Connection Display	Yes; 2 Green Link LEDs
Operating Ambient Temperature:	Horizontal Mounting, Minimum: -30°C Horizontal Mounting, Maximum: 60°C Vertical Mounting, Minimum: -30°C Vertical Mounting, Maximum: 50°C
Maximum Installation Altitude:	5 000 m
Weight:	147 g
Dimensions W x H x D (mm):	50 × 117 × 74



## DI Module Technical Specifications

Model	8DI Standard Digital Input Module	16DI Standard Digital Input Module
Order No.	P7 131-6BF01-0BA0	P7 131-6BH01-0BA0
Picture		
Product Description	DI 8x24VDC ST	DI 16x24VDC ST
Standard		
Supply Voltage	Rated Value (DC): 24 V Permissible Lower Limit (DC): 19.2 V Permissible Upper Limit (DC): 28.8 V	
Reverse Polarity Protection	√	
Power Loss, Typ.	1 W	1.7 W
Environmental Conditions		
STEP 7 TIA Portal	V14 and higher	
STEP 7 V5.5	SP3 and higher	
Number of Digital Inputs Channels	8	16
Input Characteristic Curve	IEC 61131, Type 1, 3	
Input Type	Leakage Input	
Rated Input Voltage	DC 24V	
Maximum Cable Length	Shielded: 1,000 m	
Base Unit	Unshielded: 600 m	
Diagnostic Interrupt	A0	
Diagnostic Functions	√	√
Input Delay	L+ Power Supply Missing Ground Short Circuit Wire Break Channel Enabled	L+ Power Supply Missing Wire Break Channel Enabled
Isolation Between Channels and Backplane Bus	None, 0.05 ms, 0.1 ms, 0.4 ms, 0.8 ms, 1.6 ms 3.2 ms (default), 12.8 ms, 20 ms	
Operating Ambient Temperature	√ Horizontal Mounting, Minimum: -30°C Horizontal Mounting, Maximum: 60°C Vertical Mounting, Minimum: -30°C Vertical Mounting, Maximum: 50°C	
Module Width	15mm	



## DO Module Technical Specifications

Model	8DO Standard Digital Output Module	16DO Standard Digital Output Module
Order No.	P7 132-6BF01-0BA0	P7 132-6BH01-0BA0
Picture		
Product Description	DQ 8x24VDC/0.5A ST	DI 16x24VDC ST
Standard		
Supply Voltage	Rated Value (DC): 24 V Permissible Lower Limit (DC): 19.2 V Permissible Upper Limit (DC): 28.8 V	
Reverse Polarity Protection	√	
Power Loss, Typ.	1W	
Environmental Conditions		
.STEP 7 TIA Portal	V14 and higher	
.STEP 7 V5.5	SP3 and higher	
Digital Output		
Number of Output Channels	8	16
Output Type	Source Output	
Rated Output Voltage	DC 24V	
Rated Output Current (per point)	0.5 A	
Maximum Total Output Current for Module	4A	8A
Maximum Shielded Cable Length	1,000 m	
Maximum Unshielded Cable Length	600 m	
Base Unit	A0	
Diagnostic Interrupt	√	
Diagnostic Functions	Short Circuit Wire Break Parameter Assignment Error Power Supply Voltage Missing	
Isolation Between Channels and Backplane Bus	√	
Operating Ambient Temperature	Horizontal Mounting, Minimum: -30°C Horizontal Mounting, Maximum: 60°C Vertical Mounting, Minimum: -30°C Vertical Mounting, Maximum: 50°C	
Module Width	15mm	

## 4AI Module Technical Specifications

Model	4AI Standard Analog Input Module for Current	
Order No.	P7 134-6GD01-0BA1	P7 134-6HD01-0BA1
Picture		
Product Description	AI 4xI 2-/4-wire ST	AI 4xU/I 2-wire ST
Standard		
Supply Voltage	Rated Value (DC): 24 V Permissible Lower Limit (DC): 19.2 V Permissible Upper Limit (DC): 28.8 V	
Reverse Polarity Protection	√	
Power Loss, Typ.	0.85 W	
Environmental Conditions		
.STEP 7 TIA Portal	V14 and higher	
.STEP 7	V5.6 and higher	V5.5 SP3 and higher
Number of Analog Input Channels	4	
Input Signal (Resolution)	0 to 20 mA (15-bit) 4 mA to 20 mA (15-bit) -20 mA to +20 mA (15-bit, including sign)	±5 V (16-bit, including sign) ±10 V (16-bit, including sign) 1 to 5 V (15-bit) 0 to 10 V (15-bit) 0 mA to 20 mA (15-bit) 4 mA to 20 mA (15-bit)
Conversion Time (per Channel)	180/60/50 ms	
Suppression Frequency	16.6/50/60 Hz	
Maximum Shielded Cable Length	1,000 m	1000 m, Voltage Signal 200 m
Smoothing Level	None, 4/8/16 times	
Base Unit	A0 A1	
Diagnostic Interrupt	√	
Diagnostic Functions	Power Supply Voltage Monitoring Wire Break (for 4 to 20 mA) Short Circuit (for 2-wire) Cumulative Fault Overflow/Underflow	Power Supply Voltage Monitoring Wire Break (for 4 to 20 mA) Short Circuit (for 1 to 5 V or 2-wire) Cumulative Fault Overflow/Underflow
Basic Accuracy (at 25°C)	±0.3%	
Full Temperature Range Accuracy (-30°C to 60°C)	±0.5%	
Isolation Between Channels and Backplane Bus	√	
Isolation Between Channels	√	
Operating Ambient Temperature	Horizontal Mounting, Minimum: -30°C Horizontal Mounting, Maximum: 60°C Vertical Mounting, Minimum: -30°C Vertical Mounting, Maximum: 50°C	
Module Width	15mm	

## 8AI Module Technical Specifications

Model	8AI Basic Analog Input Module for Voltage	8AI Basic Analog Input Module for Current
Order No.	P7 134-6FF00-0AA1	P7 134-6GF00-0AA1
Picture		
Product Description	AI 8xU BA	AI 8xI 2-/4-wire BA
Standard		
Supply Voltage	Rated Value (DC): 24 V Permissible Lower Limit (DC): 19.2 V Permissible Upper Limit (DC): 28.8 V	
Reverse Polarity Protection	√	
Power Loss, Typ.	0.7 W	
Environmental Conditions		
STEP 7 TIA Portal	V13 SP1 and higher	
STEP 7 V5.5	SP3 and higher	
Number of Analog Input Channels	8	
Input Signal(Resolution)	0 to +10V (15 bits) -10V to +10V (16 bits, including sign)	0 to 20mA (15 bits) 4mA to 20mA (15 bits) -20mA to +20mA (16 bits, including sign)
Interference Suppression Frequency (Hz)	16.67/50/60/4800	
Conversion Time (ms per channel)	180/60/50/0.625	
Smoothing Level	None, 4/8/16 times	
Maximum Shielded Cable Length:	200 m	
Basic Accuracy (at 25°C)	±0.3%	
Full Temperature Range Accuracy (-30°C to 60°C)	±0.5%	
Base Unit:	A0, A1	
Diagnostic Interrupt:	√	
Diagnostic Function	Power supply voltage monitoring Configuration error Overflow/Underflow	Power supply voltage monitoring Wire Break (for 4 to 20mA) Short circuit (based on module encoder power ground) Configuration error Overflow/Underflow
Isolation Between Channels and Backplane Bus	√	
Operating Ambient Temperature	Horizontal mounting, minimum: -30°C horizontal mounting, maximum: 60°C Tertical mounting, minimum: -30°C Vertical mounting, maximum: 50°C	
Module Width	15mm	

# 4AO Module Technical Specifications

Model	4AO Standard Analog Output Module
Order No.	P7 135-6HD00-0BA1

Picture



Product Description	AQ 4xU/I ST
Standard	
Supply Voltage	Rated Value (DC): 24 V Permissible Lower Limit (DC): 19.2 V Permissible Upper Limit (DC): 28.8 V
Reverse Polarity Protection	√
Power Loss, Typ.	1.5 W
Programming Environment	
STEP 7 TIA Portal	V11 SP2 and higher /V13
.STEP 7 V5.5	SP3 and higher
Number of Output Channels	4
Voltage Output Range (Resolution)	0 to 10V (15-bit) 1 to 5V (13-bit) 5 to +SV (15-bit, including sign) 10 to +10V (16-bit, including sign)
Current Output Range (Resolution)	0 to 20mA (15-bit) -20 to +20mA (16-bit, including sign) 4 to 20mA (14-bit)
Conversion Time (per Channel)	Minimum 5 ms
Basic accuracy (at 25°C)	Current: ±0.3% Voltage: ±0.3%
Full temperature range accuracy (0°C to 60°C)	Current: ±0.5% Voltage: ±0.5%
Maximum Shielded Cable Length	1000 m; 200 m for Voltage Signal
Base unit	A0, A1
Diagnostic interrupt	√
Diagnostic function	Power Supply Voltage Monitoring Wire Break Short Circuit Overflow/Underflow
Isolation Between Channels and Backplane Bus	√
Operating Ambient Temperature	<ul style="list-style-type: none"> <li>• Horizontal Mounting, Minimum: -30°C</li> <li>• Horizontal Mounting, Maximum: 60°C</li> <li>• Vertical Mounting, Minimum: -30°C</li> <li>• Vertical Mounting, Maximum: 50°C</li> </ul>
Module Width	15mm

# Light-colored base

Model	Light-colored base
Order Number	P7 193-6BP00-0DA1

Picture



Product Description	Two channels per group/ New potential group/ With TC (Temperature Compensation) BU Type A1 – Light-colored model
Standard	
Supply Voltage	Rated (DC): 24 V Internal Current Limitation Setting: 24 VDC / 10 A
Reverse Polarity Protection	√
Current Carrying Capacity	
· For P1 and P2 bus, max	max. 10 A
· For process terminals, max	2 A
Temperature Sensor	Supported
Potential Grouping	Yes
Continuation of Potential Group from Left Side	No
Insulation Test	707 V DC (Test Type)
Operating Ambient Temperature	
· Horizontal Mounting, min	-30°C
· Horizontal Mounting, max	60°C
· Vertical Mounting, min	-30°C
· Vertical Mounting, max	50°C
· Maximum Installation Altitude	5000 m; limitations apply above 2000 m
Terminals	
· Type	Push-In
· Minimum Cross-Section	0.14 mm <sup>2</sup> ; AWG 26
· Maximum Cross-Section	1.6 mm <sup>2</sup> ; AWG 16
· Number of Process Terminals for Peripheral Modules	16
· Number of AUX Bus Terminals	0
· Number of Additional Terminals	0
· Number of Terminals Connecting P1 and P2 Bus	2
Dimensions	
· Width	30mm
· Height	117mm
· Depth	40mm
Weight,	80g

## Dark-colored base

Model	Dark-colored base
Order Number	P7 193-6BP00-0BA1
Picture	
Product Description	Two channels per group/ Continuation of potential group from the left/ With TC (Temperature Compensation) BU Type A1 – Dark-colored model
Standard	
Supply Voltage	Rated (DC): 24 V Internal Current Limitation Setting: 24 VDC / 10 A
Reverse Polarity Protection	√
Current Carrying Capacity	
· For P1 and P2 bus, max	10 A
· For process terminals, max	2 A
Temperature Sensor	Supported
Potential Grouping	No
Continuation of Potential Group from Left Side	Yes
Insulation Test	707 V DC (Test Type)
Operating Ambient Temperature	
· Horizontal Mounting, min	-30°C
· Horizontal Mounting, max	60°C
· Vertical Mounting, min	-30°C
· Vertical Mounting, max	50°C
· Maximum Installation Altitude	5000 m; limitations apply above 2000 m
Terminals	
· Type	Push-In
· Minimum Cross-Section	0.14 mm <sup>2</sup> ; AWG 26
· Maximum Cross-Section	1.6 mm <sup>2</sup> ; AWG 16
· Number of Process Terminals for Peripheral Modules	16
· Number of AUX Bus Terminals	0
· Number of Additional Terminals	0
· Number of Terminals Connecting P1 and P2 Bus	2
Dimensions	
· Width	30mm
· Height	117mm
· Depth	40mm
Weight,	80g

## Features of the HD 200M Series Distributed Remote I/O

The HD 200M Series Distributed Remote I/O includes DP slave interface modules, as well as H7-300 series digital input and output modules, analog input and output modules, and temperature measurement modules. The range is comprehensive and can be flexibly configured and combined. The products have been tested through years of application in various markets and industries, demonstrating high stability, reliability, and cost-effectiveness.



- Fully compatible with all cpus of the S7-300 series and the ET200M
- Seamless connection to the S7-1500 PROFINET remote IO
- Supports the redundant system S7-400H hot-swap
- Support S7-300 and H7-300 hybrid applications, flexible configuration, high cost effective
- The TIA Portal can be used for programming

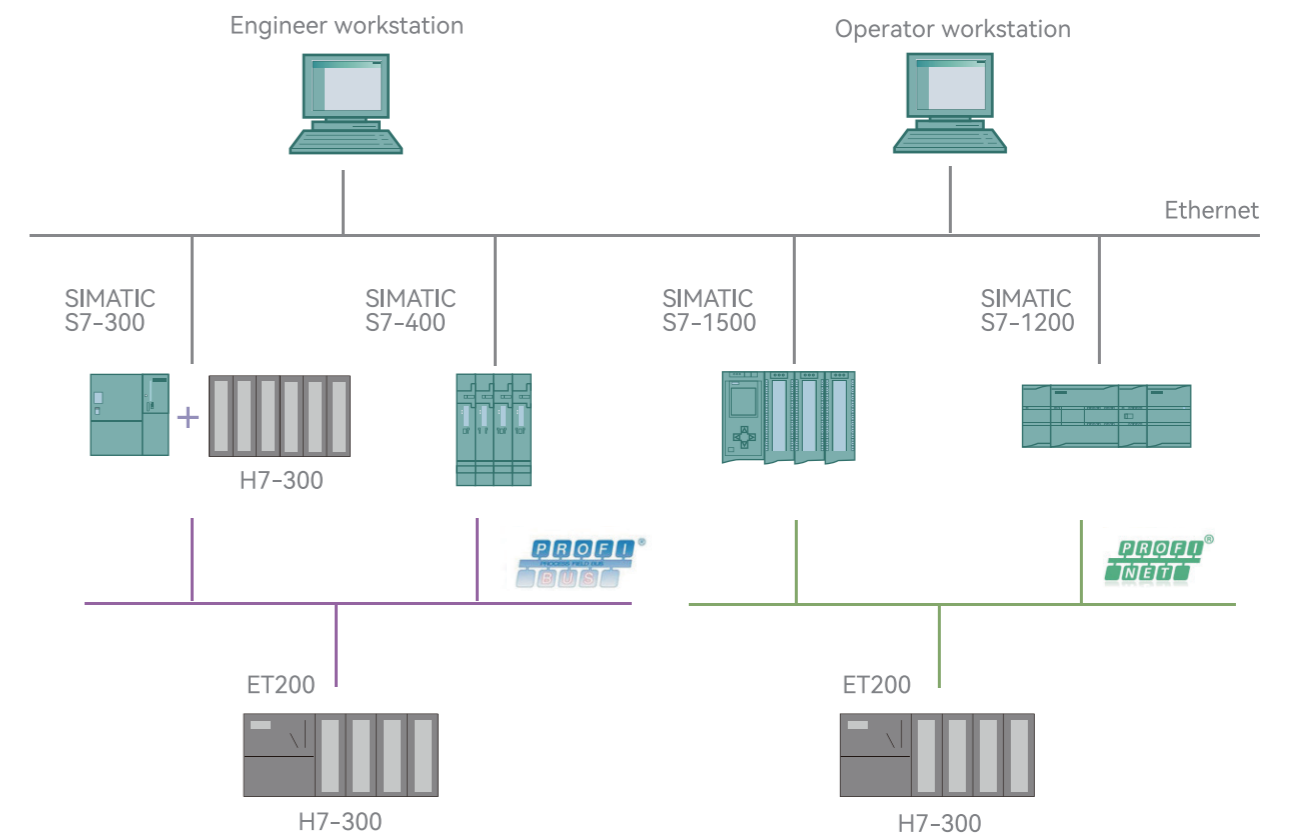

## Application Scenario

### Compatible as 300 IO module

The H7-300 PLC can be used as the IO expansion module of the S7-300 CPU, which is directly connected to the CPU through the backplane, and its application method is the same with the S7-300 PLC IO module.

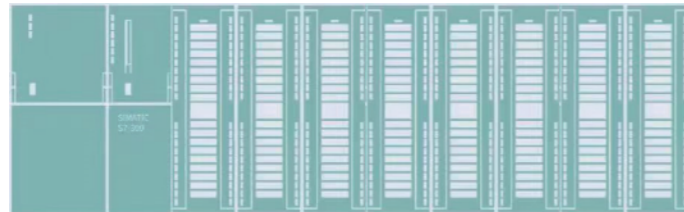

### As a slave station module for ET200M

H7-300 PLC can be used as ET200M station, it has Profibus DP bus protocol interface module, and support to connect to S7-300/S7-400 Profibus DP master station CPU.

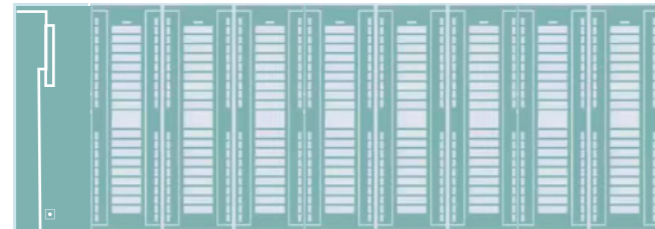

### As a slave station module of PN 153-4

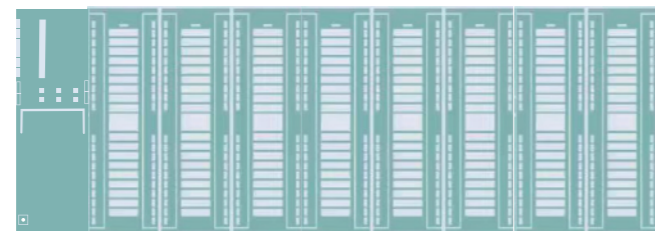

H7-300 PLC can be used as an extension of 153-4 Profinet bus protocol interface module. It supports applications as remote IO sites for Profinet main station CPUs such as the S7-1500.



## HD 200M Series Distributed Remote I/O Interface Modules

Model No.	IM153 Profibus DP Slave Interface Module
Order No.	H7 153-1AA03-0XB0
Picture	
Product Description	Interface modules for Profibus DP distributed I/O system Each slave station can connect 8 expansion modules of H7-300
Standard	
Dimension (WxHxD)	40x125x120mm
Power Consumption	3W
Supply voltage	DC 24V
Node Address	Allow 1-125
Max. expansion module	8
Communication Function	
Line protocol	PROFIBUS DP
Port	
Profibus DP output current	max. 90mA
Communication prt	
Point of junction	9-pin SUB-D
Transmission method	RS-485
Max. communication rate	12 Mbit/s automatic identification bus system
Address space	
Output (Max.)	128 Byte
Input (Max.)	128 Byte
Configuration software	STEP7/COM PROFIBUS/application software of the third party, using GSD file
Isolation voltage	500V
Output voltage	5V DC
Output current (at 5V DC)	Max. 1A (for backplane bus)

## Digital input modules

Model No.	SM 321 DI 16x24V DC	SM 321 DI 32x24V DC
Order No.	H7 321-1BH02-0AA0	H7 321-1BL00-0AA0
Picture		
Product Description	16-digital input, 24DC	32-digital input, 24DC
Standard	40x125x117mm	
Dimension(WxHxD)	40x125x117mm	
Power Consumption	Typical value 3.5W	Typical value 6.5W
Backplane bus current	30mA	35mA
Supply voltage	DC24V	
Front connector	20-pin	40-pin
Digital Input	Sinking type	
Number of Inputs	16	32
Input Type	Sinking type	
Input Voltage	24 VDC	
Rated Value	- 30 V to + 5 V	
Signal "0"	13V to 30V	
Signal "1"	-	
Input Current	Typical value 7mA	-
Input Delay	1.2ms-4.8ms	
"0" to "1" transition	1.2ms-4.8ms	
"1" to "0" transition	1.2ms-4.8ms	
Electrical isolation	Support	
Between channel group	Support	
Counting each group between channels	16	
Between channel and backplane	Support	
Encoder	Support	
2-wire system sensor	Support	
Allowable static current	Max. 1.5mA	
Cable Length(Max)	500	
Shield	300	
Unshielded	300	



## Digital output modules

Model No.	SM 322 DO 16x24V DC	SM 322 DO 16xRLY	SM 322 DO 32x24V DC
Order No.	H7 322-1BH01-0AA0	H7 322-1HH01-0AA0	H7 322-1BL00-0AA0
Picture			
Product Description	16-digital output,24VDC	16-digital output, RLY	32-digital output, 24VDC
Standard	40x125x117mm		
Dimension(WxHxD)	40x125x117mm		
Power Consumption	Typical value 4.9W		Typical value 6.6W
Backplane bus current	30mA	50mA	35mA
Supply voltage	DC24V		
Front connector	20-pin	20-pin	40-pin
Digital Output	16		
Number of Outputs	16		32
Switching frequency	max.100Hz		
Resistive load	max.100Hz	max.10Hz	max.100Hz
Inductive load	max.0.5Hz		
Lamp Load	max.10Hz	max.1Hz	max.10Hz
Output short circuit protection	Support, electronic type	Not support	Support, electronic type
Output delay	max.100us		
"0" to "1" transition	max.100us	-	max.100us
"1" to "0" transition	max.500us	-	max.500us
Electrical isolation	Support		
Between channel group	Support		
Counting each group between channels	8		
Between channel and backplane	Support		
Cable Length (Max)	500		
Shield	300		
Unshielded	300		

## Digital input/output module

Model No.	SM323 16DI/16DO
Order No.	H7 323-1BL00-0AA0
Picture	
Product Description	16-digital input /16-digital output, 24VDC
Standard	
Dimension(WxHxD)	40 x 125 x 117mm
Power Consumption	Typical value 6.5W
Backplane bus current	35mA
Supply voltage	DC24V
Front connector	40-pin
Digital Input	
Number of Inputs	16
Input Type	Sinking type
Input Voltage	
Rated Value	24 VDC
Signal "0"	-30 V to +5 V
Signal "1"	13 V to 30 V
Input Current	Typical value 7 mA
Input Delay	
"0" to "1" transition	1.2 ms-4.8 ms
"1" to "0" transition	1.2 ms-4.8 ms
Electrical isolation	
Between channel group	Support
Counting each group between channels	16
Between channel and backplane	Support
Encoder	
2-wire system sensor	Support
Allowable static current	max.1.5 mA
Digital Output	
Number of Outputs	16
Output short circuit protection	Support, electronic type
Output delay	
"0" to "1" transition	max.100 μs
"1" to "0" transition	max.500 μs
Electrical isolation	
Between channel group	Support
Counting each group between channels	8
Between channel and backplane	Support

## Analog output modules

Model No.	SM332 4AO Current/Voltage	SM332 8AO Current/Voltage
Order No.	H7 332-5HD01-0AB0	H7 332-5HF00-0AB0
Picture		
Product Description	4-chanel analog output module; Resolution 12 bits	8-chanel analog output module; Resolution 12 bits
Standard		
Dimension(WxHxD)	40 x 125 x 117mm	
Power Consumption	Typical value 3 W	
Backplane bus current	30mA	
Supply voltage	DC24V	
Front connector	20-pin	40-pin
Analog Output		
Number of Outputs	4	8
Short circuit protection	Support	
Output range		
Supply voltage	±10V、0V to 10V、1V to 5V	
Electric current	±20mA, 0mA to 20 mA, 4mA to 20mA	
Basic error limitation(operating limits at 25°C)		
Supply voltage	± 0.4 %	
Electric current	± 0.6 %	
Stability Time		
Resistive load	0.2 ms	
Capacitive load	3.3 ms	
Inductive load	0.5 ms(1mH)、3.3 ms (10mH)	
Interrupt/diagnosis/status information		
diagnosis interrupt	Can be programmable	
The diagnosis information can be readable	Support	
Resolution	12 bits	
Conversion time (each channel)	max. 0.8 ms	
Replacement value of shutdown setting	Support	Not support
Electrical isolation		
Between channel and backplane bus	Support	
Between channel and power supply	Support	
Between channel and load voltage L+	Support	
Conductor length	200m	
Maximum load capacity		
Voltage output	min. 5000Ω	
Current output	max. 500Ω	

## Analog input modules

Model No.	SM331 8AI Current/Voltage/RTD	SM331 8AI Full Function Type
Order No.	H7 331-1KF02-0AB0	H7 331-7KF02-0AB0
Picture		
Product Description	8-channel analog input; Current/voltage/RTD module Resolution 13 bits	8-channel analog input, full function temperature measurement module; External mechanical range switch; Current input with overcurrent protection; Resolution is 14 bits
Standard		
Dimension(WxHxD)	40 x 125 x 117mm	
Power Consumption	Typical value 1W	
Backplane bus current	120mA	30mA
Supply voltage	-	DC 24V
Front connector	40-pin	20-pin
Input Path		
Standard	8	
Resistive sensor	8	4
Constant current of resistive sensor		
Resistance thermometer and resistance measurement 0Ω to 600Ω	0.8mA	
Resistance measurement 0 to 6 kΩ, PTC, silicon temperature sensor	0.2mA	None
Input type and range		
Supply voltage	±50mV, ±500mV, 0V to 10V, ±1V, ±5V, ±10V, 1V to 5V	±80mV, ±250mV to ±500mV, ±1V, ±2.5V, ±5V, 1-5V, ±10V
Current (4 wires)	±20mA, 0mA to 20mA, 4mA to 20mA	±3.2mA, ±10mA, ±20mA, 0mA to 20mA, 4mA to 20mA
Current (2 wires)	-	4 mA to 20 mA
Resistor /PTC	0kΩ to 6kΩ, 0Ω to 600Ω, PTC	150Ω, 300Ω, 600Ω
RTD	Pt100 (standard/climatic) Ni100 (standard/climatic) Ni1000 (standard/climatic) LG-Ni1000 (standard/climatic) KTY83/110, KTY84/130	Pt100, Ni100
Thermocouple	None	Type E、 N、 J、 K、 L
Basic error limitation (operating limits at 25°C)		

## Analog input modules

Model No.	SM331 8AI Current/Voltage/RTD	SM331 8AI Full Function Type
Order No.	H7 331-1KF02-0AB0	H7 331-7KF02-0AB0
Supply voltage	±0.3%	±0.6%
Electric current	±0.3%	±0.5%
Resistance	±0.3%	±0.5%
Temperature	RTD Standard type: ±1K, RTD Climatic type : ±2 K	Pt100/Ni100: ±0.5 % Thermocouple: ±0.7 %
Temperature compensation		
Internal temperature compensation	None	Support
External temperature compensation via compensation socket	None	
Temperature compensation of 0°C reference junction	None	Support
Interrupt/diagnosis/status information		
Overrun interrupt	None	The channel 0 and 2
Diagnosis interrupt	None	Can be programmable
The diagnosis information can be readable	None	Support
Resolution	12 bits + symbol bits	13 bits + symbol bits
Electrical isolation		
Between channels	None	
Between channel and backplane bus	Support	
Conductor length	200m; max. 50m at 50mV	200m; 50m at 80mV, with thermocouple

# Appendix 1: Wiring Diagram of HD 200Smart Series Products

# Appendix 1: Wiring Diagram of HD 200Smart Series Products

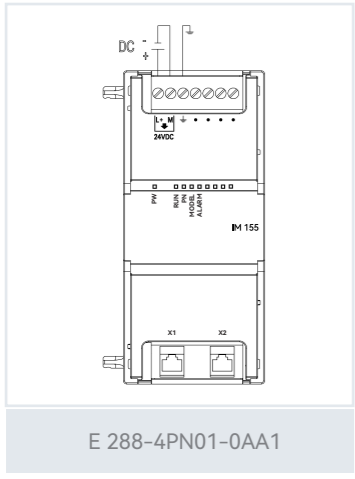

E 288-4PN01-0AA1

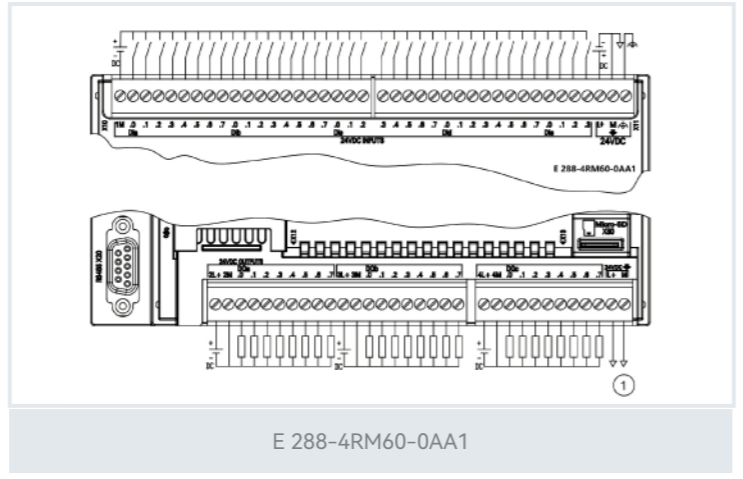

E 288-4RM60-0AA1

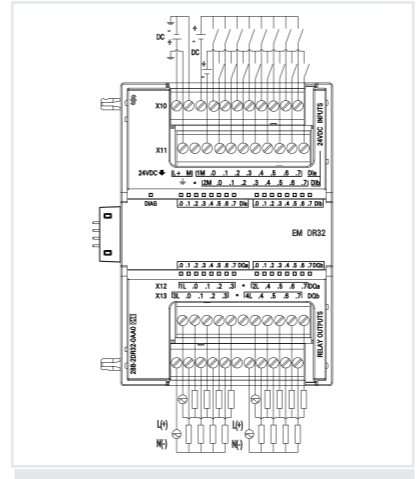

E 288-2DR32-0AA1

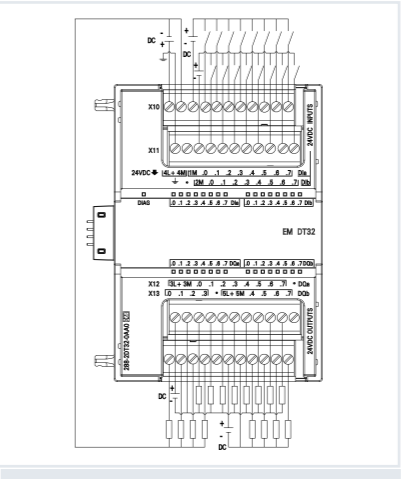

E 288-2DT32-0AA1

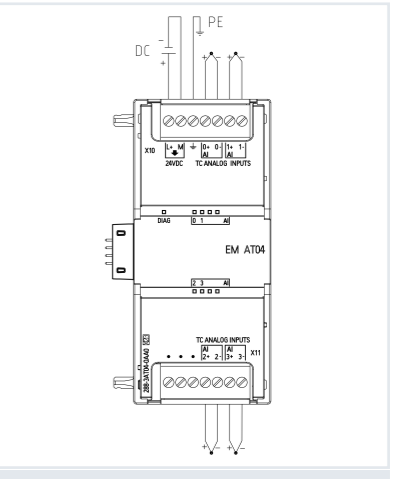

E 288-3AT04-0AA1

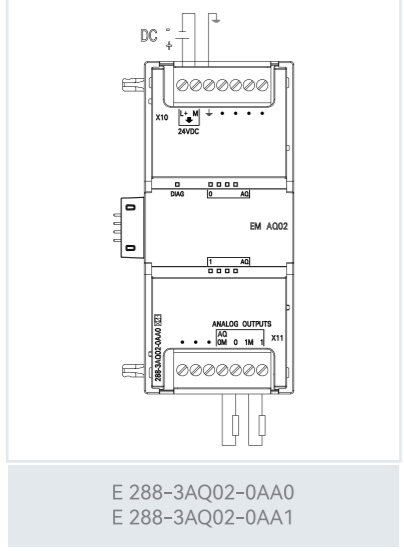

E 288-3AQ02-0AA0  
E 288-3AQ02-0AA1

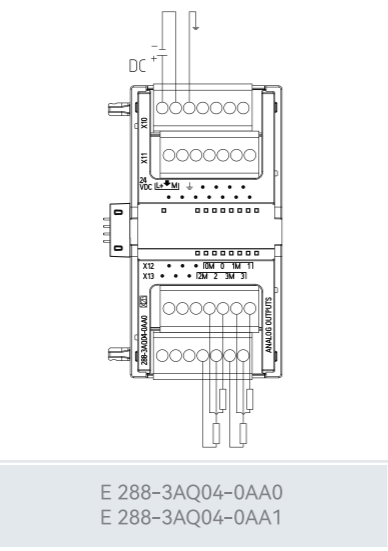

E 288-3AQ04-0AA0  
E 288-3AQ04-0AA1

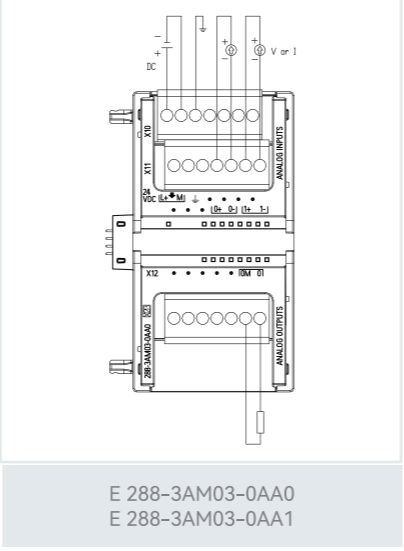

E 288-3AM03-0AA0  
E 288-3AM03-0AA1

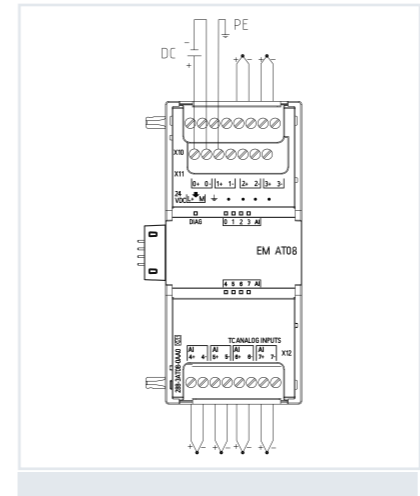

E 288-3AT08-0AA1

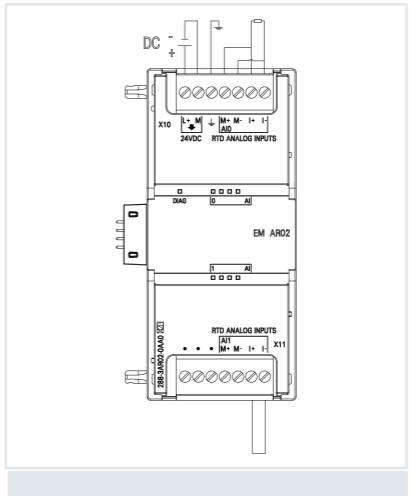

E 288-3AR02-0AA1

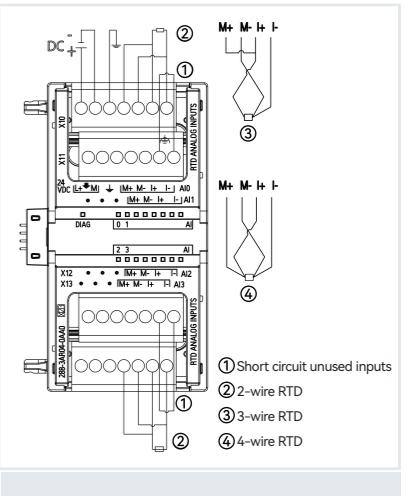

E 288-3AR04-0AA1

- ① Short circuit unused inputs
- ② 2-wire RTD
- ③ 3-wire RTD
- ④ 4-wire RTD

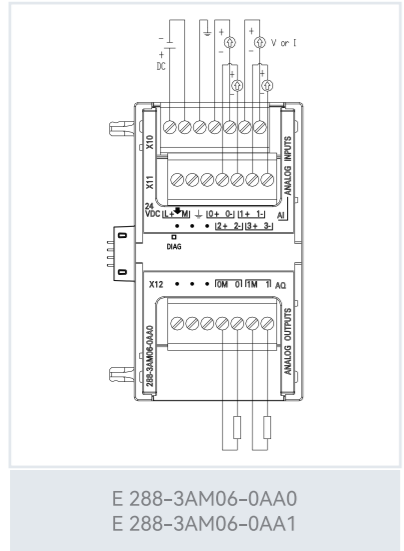

E 288-3AM06-0AA0  
E 288-3AM06-0AA1

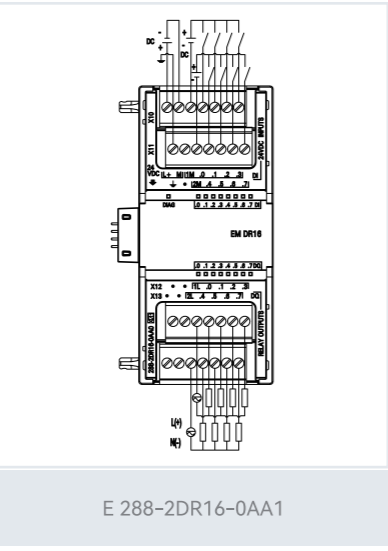

E 288-2DR16-0AA1

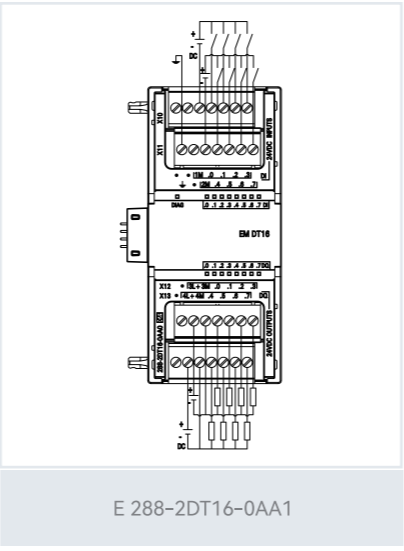

E 288-2DT16-0AA1

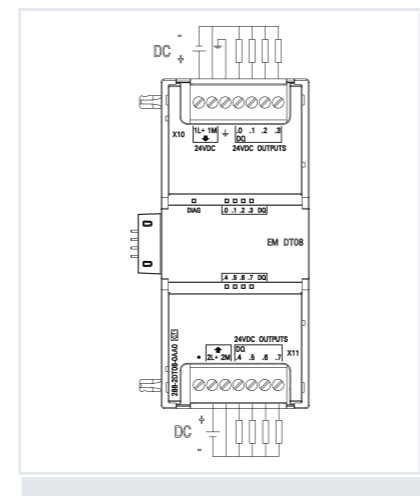

E 288-2DT08-0AA1

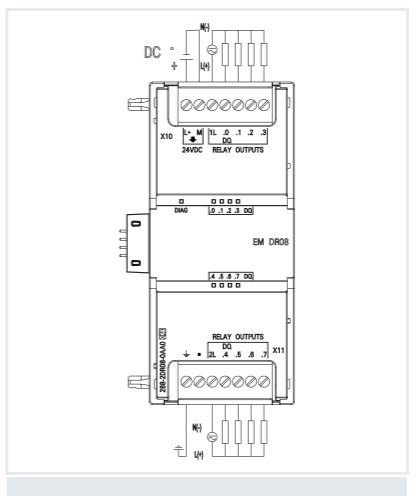

E 288-2DR08-0AA1

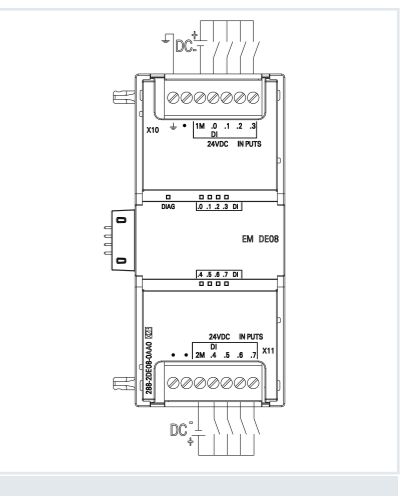

E 288-2DE08-0AA1

## Appendix 1: Wiring Diagram of HD 200Smart Series Products

## Appendix 2: Wiring Diagram of HD 200SP Series Products

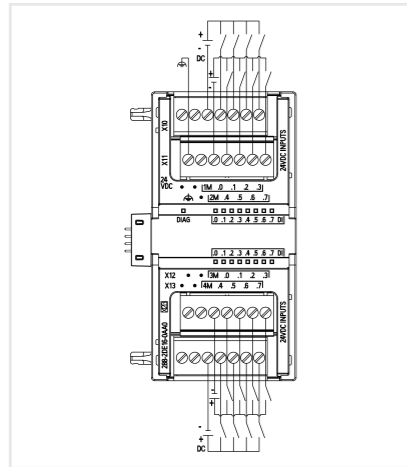

E 288-2DE16-0AA1

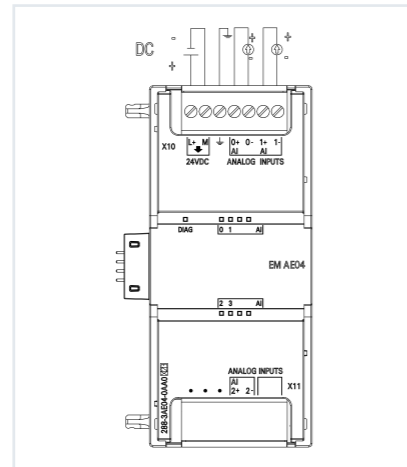

E 288-3AE04-0AA0  
E 288-3AE04-0AA1

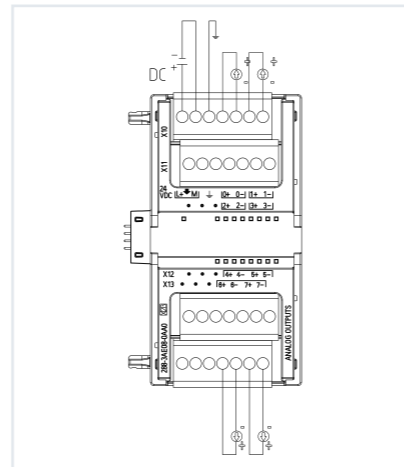

E 288-3AE08-0AA0  
E 288-3AE08-0AA1

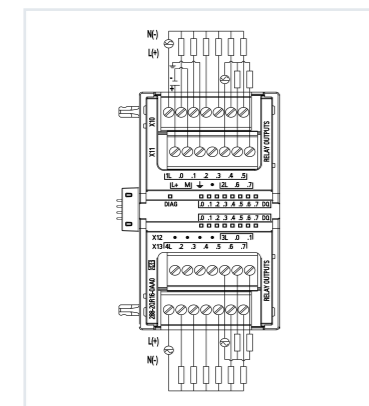

E 288-2QR16-0AA1

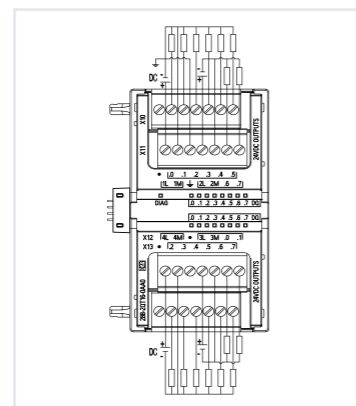

E 288-2QT16-0AA1

Pin assignment  
24V DC power supply voltage (X80)

Pin assignment  
for 24V DC power supply voltage

View		Signal name	Description
Connector	IM connection		
		1   1L+	+24V DC power supply voltage
		2   1M	Ground of the supply voltage
		3   2M	Ground of the supply voltage for loop-through
		4   2L+	The supply voltage for loop-through

1L+ and 2L+ as well as 1M and 2M are internally bridged  
Maximum 10A permitted

# 8 DI 8x24VDC ST Wiring Diagram

Connection: 1-wire and 2-wire connection

The figure below shows the block diagram and an example of the terminal assignment of the digital input module DI 8x24V DC ST on the BaseUnit BU type A0 without AUX terminals (1-wire and 2-wire connection).

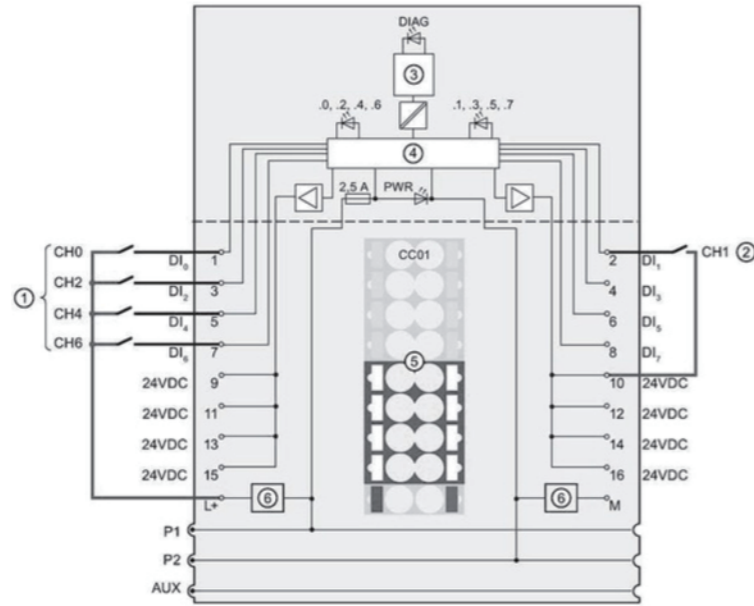

①	1-wire connection
②	2-wire connection
③	Backplane bus interface
④	Input electronics
⑤	Color identification label CCxx (optional)
⑥	Filter connection supply voltage (only when light-colored BaseUnit is present)
P1, P2, AUX	Internal self-assembling voltage buses Connection to left (dark-colored BaseUnit) Connection to left interrupted (light-colored BaseUnit)
DIn	Input signal, channel n
24 V DC	Transducer supply, channel n
L+	Feed for light-colored BaseUnit only
M	Ground
DIAG	Error or diagnostic LED (green, red)
.0 - .7	Channel status LED (green)
PWR	Power LED (green)

Wiring and block diagram for 1-wire and 2-wire connection of transducers

# 8 DI 8x24VDC ST Wiring Diagram

Connection: 3-wire connection

The figure below shows the block diagram and an example of the terminal assignment of the digital input module DI 8x24VDC ST on the BaseUnit BU type A0, with AUX terminals, for 3-wire connection.

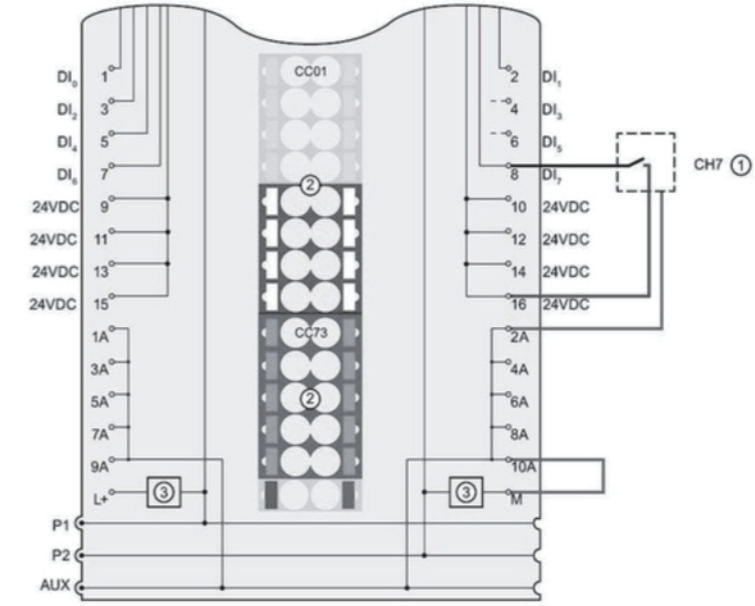

①	3-wire connection
②	Color identification label CCxx (optional)
③	Filter connection supply voltage (only when light-colored BaseUnit is present)
DIn	Input signal, channel n
L+	Feed for light-colored BaseUnit only
M	Ground
1 A EU 10 A	AUX terminals
P1, P2, AUX	Internal self-assembling voltage buses Connection to left (dark-colored BaseUnit) Connection to left interrupted (light-colored BaseUnit)

Wiring diagram and block diagram for 3-wire connection of transducers

# 16 DI 16x24VDC ST Wiring Diagram

Connection: 1-wire connection

The figure below provides an example of the block diagram and terminal assignment for the digital input module DI 16x24VDC ST on a BaseUnit BU type A0, without AUX terminals, for 1-wire connection.

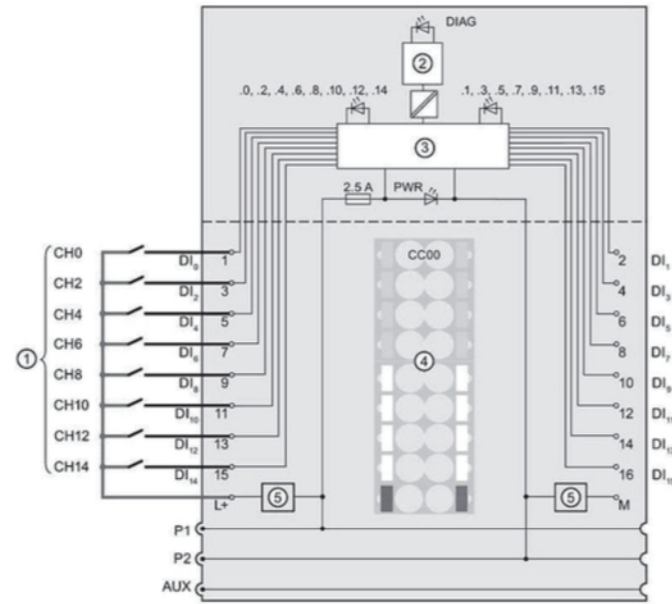

①	1-wire connection	DI	Input signal, channel n
②	Backplane bus interface	n	Feed for light-colored BaseUnit only
③	Input electronics	L+	Ground
④	Color-coded label CC00 (optional)	M	Error or diagnostic LED (green, red)
⑤	Filter connection supply voltage (only when light-colored BaseUnit is present)	0.0 - 0.15	Channel status LED (green)
P1, P2, AUX	Internal self-assembling voltage buses Connection to left (dark-colored BaseUnit) Connection to left interrupted (light-colored BaseUnit)	PWR	Power LED (green)

Wiring diagram and block diagram for 1-wire connection of transmitter

# 8 DQ 8x24VDC/0.5A ST Wiring Diagram

Connection: 1-wire and 2-wire connection for actuators

The figure below shows an example of the terminal assignment for the digital output module DQ 8x24VDC/0.5A ST on the BaseUnit BU type A0, without AUX terminals, for 1-wire and 2-wire connections.

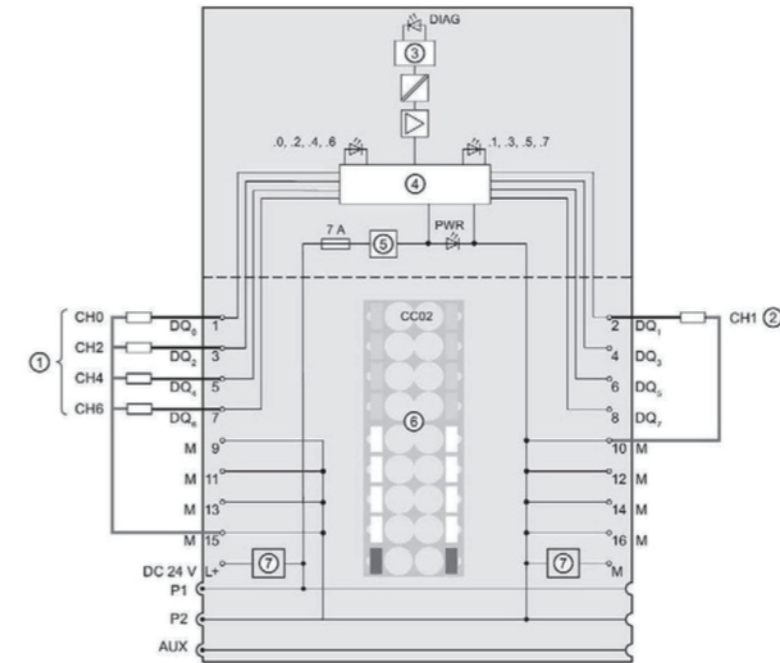

①	1-wire connection	24 V D C	Power supply L+ (Feed for light-colored BaseUnit only)
②	2-wire connection	M	Ground
③	Backplane bus interface	P1, P2, AUX	Internal self-assembling voltage buses Connection to left (dark-colored BaseUnit) Connection to left interrupted (light-colored BaseUnit)
④	Output electronics	DQn	Output signal, channel n
⑤	Reverse polarity protection	DIAG	Error or diagnostic LED (green, red)
⑥	Color-coded label CC02 (optional)	.0 - .7	Channel status LED (green)
⑦	Filter connection supply voltage (only when light-colored BaseUnit is present)	PWR	Power LED (green)

Block diagram and terminal assignment for 1-wire and 2-wire connection of actuators

### Wire-break detection

If the module is configured with wire-break detection, a low quiescent current is required at the digital input when monitoring a "0" signal. To ensure the flow of this quiescent current when the mechanical transducer contacts are open, a 25 kΩ to 45 kΩ resistor must be connected in parallel.

If wire-break detection is disabled in the configuration, no parallel resistor is required

If wire-break detection is configured, a 25 kΩ to 45 kΩ resistor must be connected in parallel to each mechanical transducer contact.

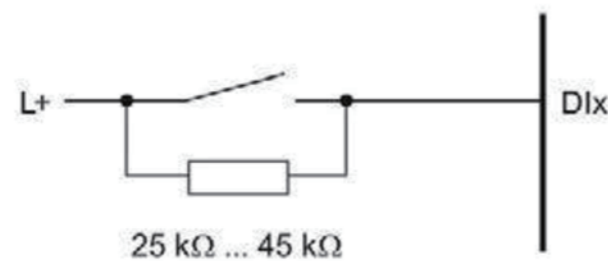

Connecting the resistor to the mechanical transducer contacts

## 8 DQ 8x24VDC/0.5A ST Wiring Diagram

Connection: 3-wire connection for actuators

The figure below shows an example of the terminal assignment for the digital output module DQ 8x24VDC/0.5A ST on the BaseUnit BU type A0, with AUX terminals, for 3-wire connection.

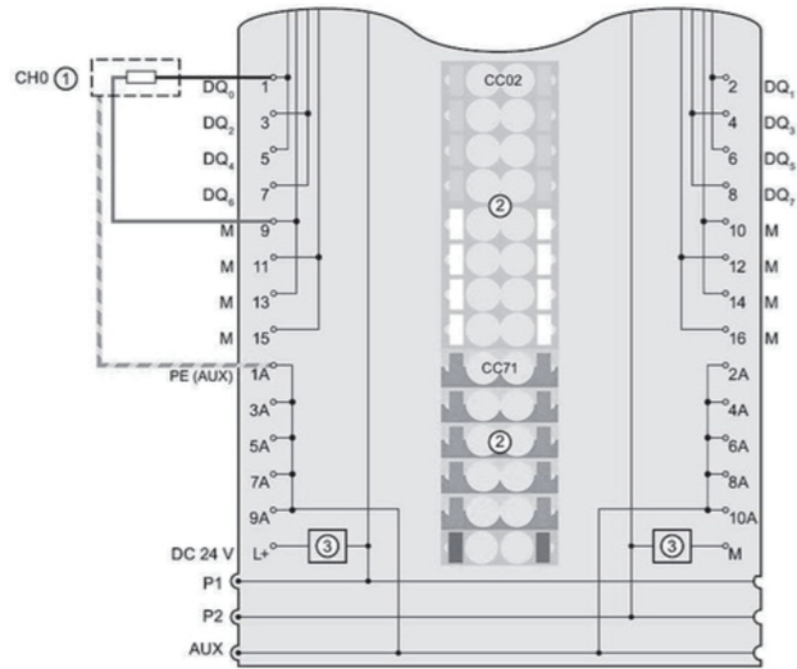

①	3-wire connection	1A-10A	1A to 10A AUX terminals
②	Color-coded labels CC02 and CC71 (optional)	PE (AUX)	PE (AUX) Protective conductor connection
③	Filter connection supply voltage (only when light-colored BaseUnit is present)	24 V DC	Power supply L+ (only for powering the light-colored BaseUnit)
DQn	Output signal, channel n	M	Ground
		P1, P2, AUX	Internal self-assembling voltage buses Connection to left (dark-colored BaseUnit) Connection to left interrupted (light-colored BaseUnit)

Terminal assignment for 3-wire connection of actuators

## 16 DQ 16x24VDC/0.5A ST Wiring Diagram

Connection: 1-wire connection for actuators

The figure below shows the block diagram and an example of the terminal assignment for the digital output module DQ 16x24VDC/0.5A ST on the BaseUnit BU type A0 (1-wire connection).

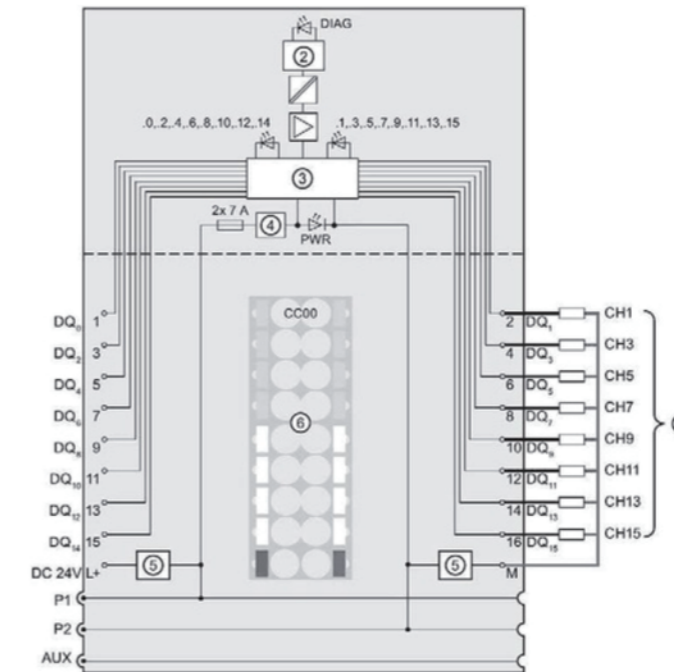

①	1-wire connection	DQ n	Output signal, channel n
②	Backplane bus interface	24 V DC	Power supply L+ (Feed for light-colored BaseUnit only)
③	Output electronics	M	Ground
④	Reverse polarity protection	P1, P2 AUX	Internal self-assembling voltage buses Connection to left (dark-colored BaseUnit) Connection to left interrupted (light-colored BaseUnit)
⑤	Filter connection supply voltage (only when light-colored BaseUnit is present)	DIAG	Diagnostics LED (green, red)
		.0 - .15	Channel status LED (green)
⑥	Color-coded label CC02 (optional)	PWR	Power LED (green)

Block diagram and terminal assignment for 1-wire connection of actuators

## AI 4xI 2-/4-wire ST wiring diagram

Connection: 2-wire and 4-wire connections for current measurement (2-wire and 4-wire waste feeders)

The following figure shows the block diagram and terminal allocation example of the analog input module AI 4 × I 2-/4-wire ST on a BaseUnit with BU type AO/A1.

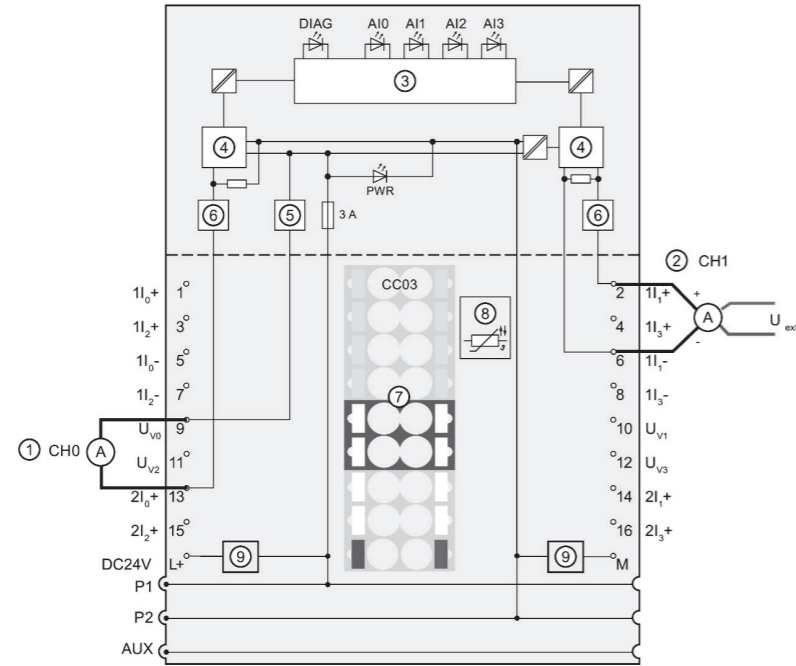

①	2-wire connection for current measurement (2-wire transmitter)	1In+	Current input (positive), channel n
②	4-wire connection for current measurement (4-wire transmitter)	1In-	Current input (negative), channel n
③	Backplane bus interface	UVn	Power supply voltage, channel n
④	Analog to Digital Converter (ADC)	2In+	Current input (positive), channel n
⑤	short circuit protection	L+	24V DC (only for light colored BaseUnit power supply)
⑥	Current limit	M	Ground
⑦	Color coding label for CC03 (optional)	P1, P2, AUX	Internal self-assembled voltage bus Connect to the left side (dark BaseUnit) Connect to the left interrupt (light colored BaseUnit)
⑧	Only record the temperature of BU type A1 (module does not support this function)	DIAG	Diagnostic LED indicator light (green red)
⑨	Uext External encoder power supply	AI0, AI1, AI2, AI3	Channel status LED indicator light (green)
		PWR	Power LED indicator light (green)

Wiring diagram and block diagram for current measurement when connecting 2-wire and 4-wire systems (2-wire and 4-wire transmitters)

## AI 4xU/I 2-wire ST wiring diagram

Connection: Voltage and current measurement for 2-wire connection

The following figure shows the block diagram and terminal allocation example of the analog input module AI 4 × U/I 2-wire ST on a BaseUnit with BU type AO/A1.

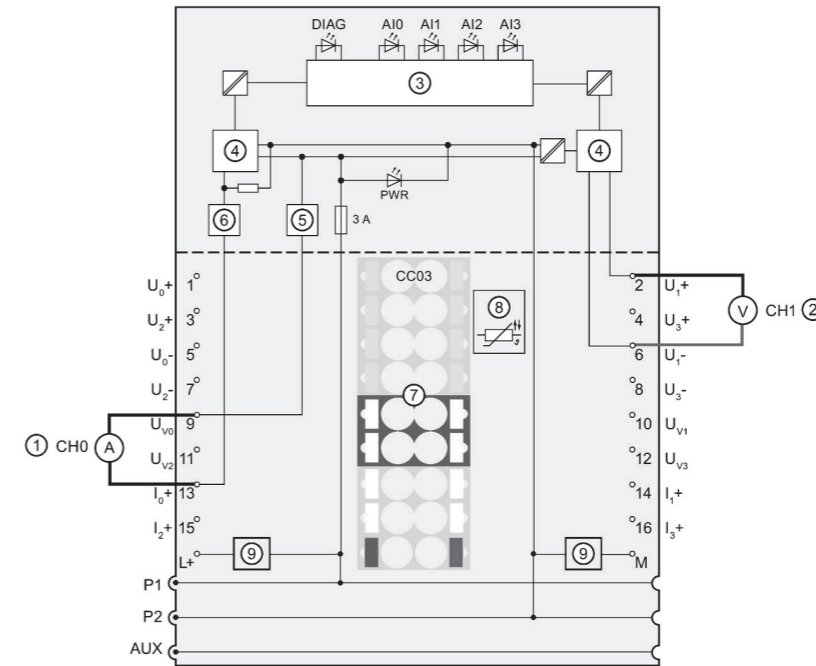

①	2-wire connection for current measurement (2-wire transmitter)	1In+	Voltage input (positive), channel n
②	2-wire connection for voltage measurement	1In-	Voltage input (negative), channel n
③	Backplane bus interface	UVn	Power supply voltage, channel n
④	Analog to Digital Converter (ADC)	2In+	Current input (positive), channel n
⑤	short circuit protection	L+	24V DC (only for light colored BaseUnit power supply)
⑥	Current limit	M	Ground
⑦	Color coding label for CC03 (optional)	P1, P2, AUX	Internal self-assembled voltage bus Connect to the left side (dark BaseUnit) Connect to the left interrupt (light colored BaseUnit)
⑧	Only record the temperature of BU type A1 (module does not support this function)	DIAG	Diagnostic LED indicator light (green red)
⑨	Power supply voltage filtering circuit (currently only light colored BaseUnit)	AI0, AI1, AI2, AI3	Channel status LED indicator light (green)
		PWR	Power LED indicator light (green)

Wiring and block diagram for voltage and current measurement

# AI 8xU BA Wiring Diagram

Connection: 2-wire voltage measurement connection

The figure below shows the block diagram and terminal assignment example of the analog input module AI 8xU BA on BaseUnit BU type A0/A1.

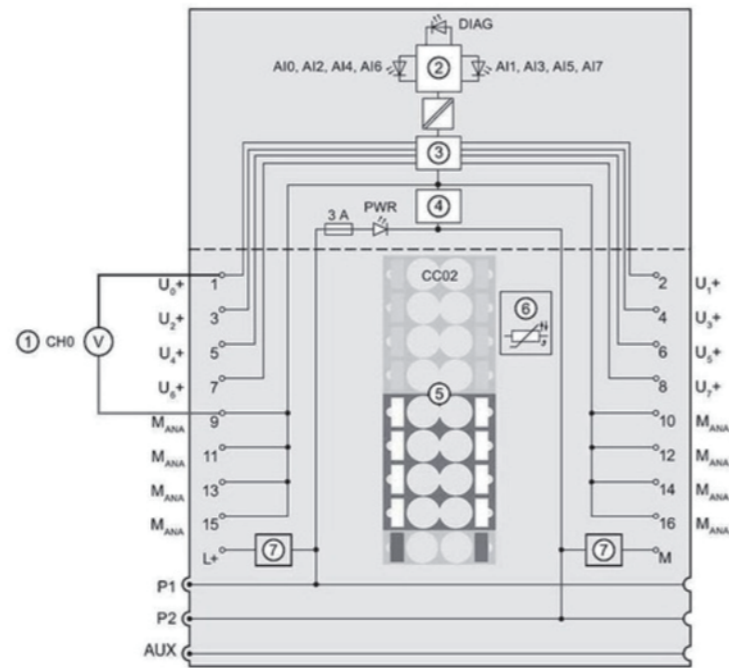

① 2-wire connection for voltage measurement	Un+	Voltage input (positive), channel n
② Backplane bus interface	MANA	Ground for analog input
③ Analog-to-digital converter (ADC)	L+	Infeed only with light-colored BaseUnit
④ Current limitation	M	Ground
⑤ Color-coded label CCxx (optional)	P1、 P2	Internal self-assembling voltage buses
	AUX	Connection to left (dark-colored BaseUnit) Connection to left interrupted (light-colored BaseUnit)
⑥ Temperature recording for BU type A1 only (function cannot be used for this module)	DIAG	Diagnostic LED (green, red)
⑦ Filtered power supply voltage connection (only when a light-colored baseUnit is present)	AI0 - AI7	Channel status LED (green)
	PWR	Power LED (green)

The wiring diagram and block diagram for 2-wire voltage measurement connection.

# AI 8xI 2-/4-wire BA Wiring Diagram

Connection: Current measurement 2-wire connection

The figure below shows the block diagram and an example of the terminal assignment of the analog input module AI 8xI 2-/4-wire BA on the BaseUnit BU type A0/A1.

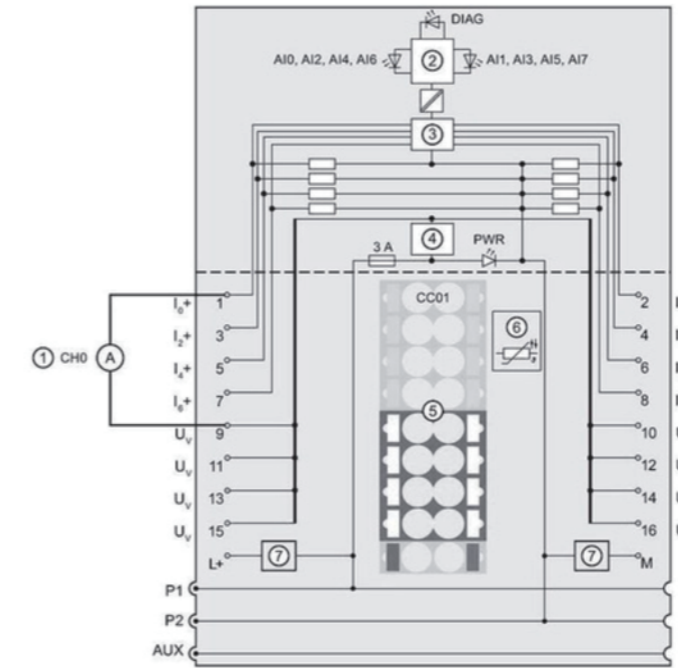

① 2-wire connection for current measurement	In+	Input signal, channel n
② Backplane bus interface	UV	Infeed voltage
③ Analog-to-digital converter (ADC)	L+	Infeed for light-colored BaseUnit only
④ Current limitation	M	Ground
⑤ Color-coded label CCxx (optional)	P1、 P2	Internal self-assembling voltage buses
	AUX	Connection to left (dark-colored BaseUnit) Connection to left interrupted (light-colored BaseUnit)
⑥ Temperature recording for BU type A1 only (function cannot be used for this module)	DIAG	Diagnostic LED (green, red)
⑦ Filtered power supply voltage connection (only when a light-colored BaseUnit is present)	AI0 - AI7	Channel status LED (green)
	PWR	Power LED (green)

Wiring diagram and block diagram for 2-wire connection in current measurement.

# AQ 4xU/I ST Wiring Diagram

General terminal assignment

Terminal assignment for AQ 4xU/I ST (P7 135-6HD00-0BA1)						
Terminal	Assignment	Terminal	Assignment	Description	BaseUnit	Color identification labels
1	Q <sub>0</sub> <sup>+</sup>	2	Q <sub>1</sub> <sup>+</sup>	<ul style="list-style-type: none"> <li>Analog output voltage/current (negative), channel n</li> </ul>	<b>A0</b> <b>A1</b>	---
3	Q <sub>2</sub> <sup>+</sup>	4	Q <sub>3</sub> <sup>+</sup>			
5	Q <sub>0</sub> <sup>-</sup>	6	Q <sub>1</sub> <sup>-</sup>			
7	Q <sub>2</sub> <sup>-</sup>	8	Q <sub>3</sub> <sup>-</sup>	<ul style="list-style-type: none"> <li>Analog output voltage/current (positive), channel n</li> </ul>		
9	S <sub>0</sub> <sup>+</sup>	10	S <sub>1</sub> <sup>+</sup>	<ul style="list-style-type: none"> <li>Sensor line (positive), channel n</li> </ul>		
11	S <sub>2</sub> <sup>+</sup>	12	S <sub>3</sub> <sup>+</sup>			
13	S <sub>0</sub> <sup>-</sup>	14	S <sub>1</sub> <sup>-</sup>			
15	S <sub>2</sub> <sup>-</sup>	16	S <sub>3</sub> <sup>-</sup>	<ul style="list-style-type: none"> <li>Sensor line (negative), channel n</li> </ul>		
L+	24 VDC	M	M			

<p>Voltage 2-wire connection</p>	<p>Voltage 3-wire connection</p>	<p>Voltage 4-wire connection</p>	<p>Current</p>
----------------------------------	----------------------------------	----------------------------------	----------------

The available BaseUnit type can be identified by the last two digits of the order number.

# Light-colored base Series Products

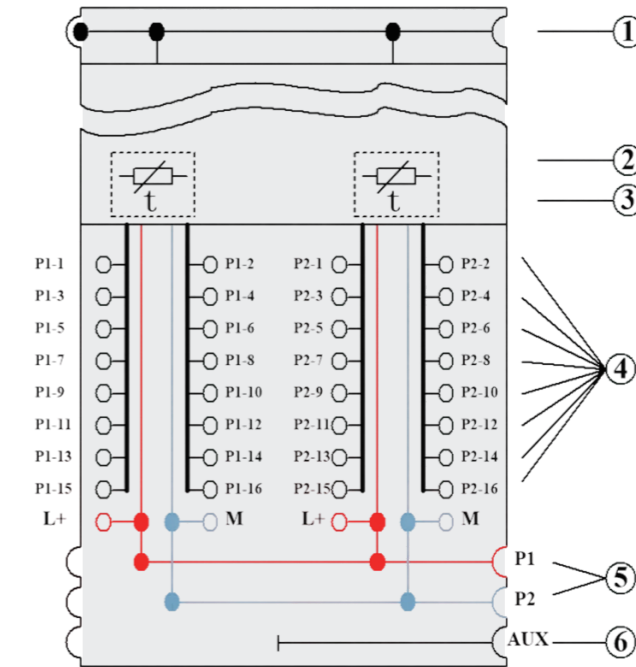

- ① Backplane bus slots ×2
- ② I/O modules ×2
- ③ Internal reference compensation chip
- ④ Terminals for linking I/O modules
- ⑤ System-integrated, self-assembled voltage buses P1 and P2: connect to power supply terminals, disconnected from the adjacent module on the left (forming a new potential group)
- ⑥ System-integrated, self-assembled AUX voltage bus: not connected to AUX terminals, disconnected from the adjacent module on the left (forming a new potential group)

# Dark-colored base Series Products

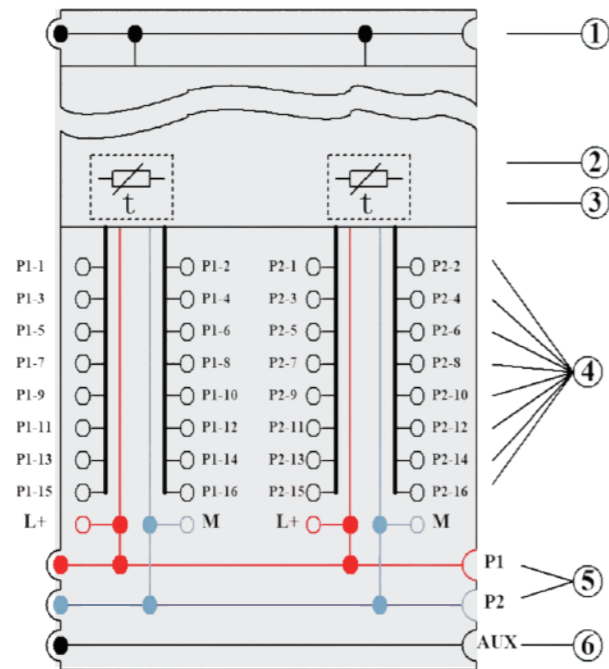

①	Backplane bus slots ×2
②	I/O modules ×2
③	Internal reference compensation chip
④	Terminals for linking I/O modules
⑤	System-integrated, self-assembled voltage buses P1 and P2: connected to power supply terminals and to the adjacent module on the left
⑥	System-integrated, self-assembled AUX voltage bus: not connected to AUX terminals, connected to the adjacent module on the left

# Appendix 3: Wiring Diagram of HD 200M Series Products

## Appendix 4: Ordering Data

### HD 200Smart Series Distributed Remote I/O

Model	Product Description	Order Number
IM 155	Profinet interface module, Expandable to 16 E-series I/O Modules, 2*RJ45	E 288-4PN01-0AA1
IM 60	Profinet interface module, Expandable to 16 E-series I/O Modules, 36DI/24DO, 1*RJ45, 1*RS485	E 288-4RM60-0AA1

### E 200Smart Digital Module

Model no.	Description	Order no.
E DE08	EM DE08 Digital Input Modules, 8DI, 24VDC	E 288-2DE08-0AA1
E DE16	EM DE16 Digital Input Modules, 16DI, 24VDC	E 288-2DE16-0AA1
E DR08	EM DR08 Digital Output Modules, 8DO, Relay output	E 288-2DR08-0AA1
E DT08	EM DT08 Digital Output Modules, 8DO, Transistor output	E 288-2DT08-0AA1
E QR16	EM QR16 Digital Output Modules, 16DO, Relay output	E 288-2QR16-0AA1
E QT16	EM QT16 Digital Output Modules, 16DO, Transistor output	E 288-2QT16-0AA1
E DR16	EM DR16 Digital Input/Output Modules, 8DI/8DO, Relay output	E 288-2DR16-0AA1
E DT16	EM DT16 Digital Input/Output Modules, 8DI/8DO, Transistor output	E 288-2DT16-0AA1
E DR32	EM DR32 Digital Input/Output Modules, 16DI/16DO, Relay output	E 288-2DR32-0AA1
E DT32	EM DT32 Digital Input/Output Modules, 16DI/16DO, Transistor output	E 288-2DT32-0AA1

### E 200Smart Analog Module Unipolar Version (Unipolarity)

Model no.	Description	Order no.
E AE04	EM AE04 Analog Input Modules, 4AI, 0-20mA/0-10V	E 288-3AE04-0AA1
E AE08	EM AE08 Analog Input Modules, 8AI, 0-20mA/0-10V	E 288-3AE08-0AA1
E AQ02	EM AQ02 Analog Output Modules, 2AO, 0-20mA/0-10V	E 288-3AQ02-0AA1
E AQ04	EM AQ04 Analog Output Modules, 4AO, 0-20mA/0-10V	E 288-3AQ04-0AA1
E AM03	EM AM03 Analog Input/Output Modules, 2AI/1AO, 0-20mA/0-10V	E 288-3AM03-0AA1
E AM06	EM AM06 Analog Input/Output Modules, 4AI/2AO, 0-20mA/0-10V	E 288-3AM06-0AA1

### E 200Smart Analog Module Bipolar Version (Bipolar)

Model no.	Description	Order no.
E AE04-b	EM AE04 Analog Input Modules, 4AI, 0-20mA/±2.5V/±5V/±10V	E 288-3AE04-0AA0
E AE08-b	EM AE08 Analog Input Modules, 8AI, 0-20mA/±2.5V/±5V/±10V	E 288-3AE08-0AA0
E AQ02-b	EM AQ02 Analog Output Modules, 2AO, 0-20mA/±10V	E 288-3AQ02-0AA0
E AQ04-b	EM AQ04 Analog Output Modules, 4AO, 0-20mA/±10V	E 288-3AQ04-0AA0
E AM03-b	EM AM03 Analog Input/Output Modules, 2AI/1AO, 0-20mA/±2.5V/±5V/±10V	E 288-3AM03-0AA0
E AM06-b	EM AM06 Analog Input/Output Modules, 4AI/2AO, 0-20mA/±2.5V/±5V/±10V	E 288-3AM06-0AA0

### E 200Smart Temperature Measurement Module (Temperature measurement)

Model no.	Description	Order no.
E AR02	EM AR02 Thermal Resistor Input Module, 2RTD	E 288-3AR02-0AA1
E AR04	EM AR04 Thermal Resistor Input Module, 4RTD	E 288-3AR04-0AA1
E AT04	EM AT04 Thermocouple Input Module, 4TC	E 288-3AT04-0AA1
E AT08	EM AT08 Thermocouple Input Module, 8TC	E 288-3AT08-0AA1

### HD 200SP Series Distributed Remote I/O

Model	Product Description	Order No.
155-6 Standard Module	IM155-6 PN Interface Module Integrated with 2RJ45 ports	P7 155-6AA01-0BN0
8DI Standard Digital input Module	DI 8x24VDC ST	P7 131-6BF01-0BA0
16DI Standard Digital input Module	DI 16x24VDC ST	P7 131-6BH01-0BA0
8DO Standard Digital Output Module	DQ 8x24VDC/0.5A ST	P7 132-6BF01-0BA0
16DO Standard Digital Output Module	DQ 16x24VDC/0.5A ST	P7 132-6BH01-0BA0
4AI Standard Analog Input Module for Current	AI 4xI 2-/4-wire ST	P7 134-6GD01-0BA1
4AI Standard Analog Input Module for Voltage and Current	AI 4xU/I 2-wire ST	P7 134-6HD01-0BA1
8AI Basic Analog Input Module for Voltage	AI 8xU BA	P7 134-6FF00-0AA1
8AI Basic Analog Input Module for Current	AI 8xI 2-/4-wire BA	P7 134-6GF00-0AA1
4AO Standard Analog Output Module	AQ 4xU/I ST	P7 135-6HD00-0BA1
Light-colored base	Two channels per group/ New potential group/ With TC (Temperature Compensation) BU Type A1 – Light-colored model	P7 193-6BP00-0DA1
Dark-colored base	Two positions per group / Left-side continuation of potential group / With TC temperature compensation, BU Type A1, dark-colored model	P7 193-6BP00-0BA1

### HD 200M Series Distributed Remote I/O

Model	Product Description	Order Number
IM 153-1	Profibus DP Interface Modules	H7 153-1AA03-0XB0

Digital module		Article No.
SM321	Digital input module, 16DI	H7 321-1BH02-0AA0
SM321	Digital input module, 32DI	H7 321-1BL00-0AA0
SM322	Digital output module, 16DO	H7 322-1BH01-0AA0
SM322	Digital output module, 16DO, Electric Relay, 2A	H7 322-1HH01-0AA0
SM322	Digital output module, 32DO	H7 322-1BL00-0AA0
SM323	Digital input/output module, 16DI/16DO	H7 323-1BL00-0AA0
Analog Module		Article No.
SM331	Analog input module, 8AI, Electric current/Supply voltage/Hot resistance	H7 331-1KF02-0AB0
SM331	Analog input module, 8AI, Intelligent	H7 331-7KF02-0AB0
SM332	Analog output module, 4AO	H7 332-5HD01-0AB0
SM332	Analog output module, 8AO	H7 332-5HF00-0AB0

Other accessories

300 Guide rail		Article No.
Guide rail	Installing guide rails 160mm	H7 390-1AB60-0AA0
Guide rail	Installing guide rails 483mm	H7 390-1AE80-0AA0
Guide rail	Installing guide rails 530mm	H7 390-1AF30-0AA0
Guide rail	Installing guide rails 830mm	H7 390-1AJ30-0AA0
Guide rail	Active guide rail, Hot swappable 483mm	H7 195-1GA00-0XA0
Guide rail	Active guide rail, Hot swappable 530mm	H7 195-1GF30-0XA0
Guide rail	Active guide rail, Hot swappable 620mm	H7 195-1GG30-0XA0
300 Front connector		Article No.
Front connector	20-pin front connector Screw type	H7 392-1AJ00-0AA0
Front connector	40-pin front connector Screw type	H7 392-1AM00-0AA0
PROFIBUS Product		Article No.
Bus connector	PROFIBUS Bus connector 90 degree outlet without programming port	H7 972-0BA12-0XA0
Bus connector	PROFIBUS Bus connector 90 degree outlet without programming port	H7 972-0BB12-0XA0
Bus connector	PROFIBUS Bus connector 35 degree outlet without programming port	H7 972-0BA41-0XA0
Bus connector	PROFIBUS Bus connector 35 degree outlet without programming port	H7 972-0BB41-0XA0
Bus cable	PROFIBUS Bus cable Two-core shielded twisted pair cable in Purple color	H7 830-0EH10
PROFINET Product		Article No.
Connector	PROFINET connector 90 degree outlet	H7 901-1BG10-0XA0
Connector	PROFINET connector 180 degree outlet	H7 901-1BB10-0XA0
Cable	PROFINET Cable, Four-core shielded twisted pair cable in Green color	H7 840-2AH10

## Service and Warranty

The stage behind is the key to success, and after-sales service is the guarantee of life



### 3 years warranty

Within 3 years from the date of delivery, we can offer the unconditional free maintenance once occurring product quality problem.



### Lifetime maintenance

We offer lifelong maintenance and repair services for the users of HUCEEN products